



CLASSIFICATION REPORT no. 09 - A - 159

According to standards EN 15650: 2010 and EN 13501-3: 2007

Regarding A range of "CU-LT"-type fire dampers
Operating vacuum pressure: - 500Pa

Sponsor RF TECHNOLOGIES
Lange Ambachtstraat, 40
B - 9860 OOSTERZELE

This document may only be reproduced in its entirety. Partial reproduction is forbidden.

1. INTRODUCTION

This classification report defines the classification assigned to a range of "CU-LT"-type fire dampers in accordance with the procedures set out in the standard EN 13501-3: 2007 "Fire classification of construction products and building elements - Part 3: Classification using data from fire resistance tests, on products and elements used in building service installations: fire resisting ducts and fire dampers" and in the standard EN 15650: 2010 "Ventilation for buildings. Fire dampers".

2. BODY

EFECTIS France
Voie Romaine
F - 57280 MAIZIERES-LES-METZ

3. SPONSOR

RF TECHNOLOGIES
Lange Ambachtstraat, 40
B - 9860 OOSTERZELE

4. REFERENCE AND ORIGIN OF THE TEST SPECIMENS

Reference: CU-LT
Origin: RF TECHNOLOGIES
Lange Ambachtstraat, 40
B - 9860 OOSTERZELE

5. OVERALL PRINCIPLE

5.1. TYPE OF FUNCTION

The "CU-LT"-type damper is defined as a "fire damper". Its function is to be fire-resistant as regards fire integrity, thermal insulation and leakage flow rates.

5.2. GENERAL POINTS

Each fire damper is composed of a tunnel, within which a horizontally-mounted mobile blade pivots using an external mechanism and a transmission.

Approved fire dampers have flow cross-section dimensions of between 200 x Ø 100mm and 800 x Ø 600mm (w x h).

5.3. DETAILED DESCRIPTION OF THE ELEMENTS

5.3.1. Fire damper casing

Each fire damper is composed of a galvanised steel duct with (W-6) x (H-6) mm, 0.8mm thick and 300mm long. At each end, the fire damper's tunnel is fitted with a steel clamp. At each corner, the clamps are fixed together in pairs using a steel bracket attached to each clamp by two aluminium rivets (\varnothing 4.8mm).

Level with the fire damper blade, the circumference of the casing was perforated with 20 x 3mm holes, at 3mm intervals over a width of 9mm.

On the inside, the perforations are completely covered by graphite, self-adhesive, intumescent tape with dimensions of 44 x 2mm (RECTORSEAL). A 60mm-wide strip of self-adhesive PP (TESA) tape is placed on the intumescent tape.

To guarantee its stiffness, the tunnel's sheet metal is bent over along the perforations described above at a height of 20mm. These bends act as reinforcement.

Inside the tunnel, EPDM-type gasket seals are placed on the semi-periphery above and below the damper blade.

Four brackets are used, in pairs, to hold the metal plates described above in place. They are fixed using two aluminium rivets (\varnothing 4.8mm) on each plate. Each of the brackets has a steel lug which can be bent in order to demarcate the seal limit.

Halfway up, the fire damper casing has two openings (\varnothing 12mm and \varnothing 18mm) on the mechanism side, which allow the hinge pin of the fire damper blade to pass through, and five openings (\varnothing 5mm), which are used to fix the transmission housing using aluminium rivets (\varnothing 4.8mm).

5.3.2. Blade

The blade is made of a 25mm-thick Promatect H plate.

On the outer edge of the blade, a groove with dimensions of 15 x 2mm (w x d) is machined.

Two galvanized steel hinge pin brackets, with cross section dimensions of 80 x 40mm are fixed on the blade using two bolt (M5 x 30mm). The pin is fixed to the brackets using two bolts (M5 x 16mm).

The blade pivots on a steel hinge pin, with cross section dimensions of 10 x 10mm.

The pin rests on two brass bearings (\varnothing 12 x 14.5mm and \varnothing 18 x 9.5mm) on the mechanism side, fitted in the fire damper casing.

The clearance between the blade and the fire damper casing is approximately 4mm.

5.3.3. Mechanism

The control mechanism is fully installed on the outside of the fire damper and is composed of the following elements:

- A BLF (BELIMO) actuator
- A mounting section
- A transmission mechanism
- A thermal fuse

The actuator is connected to the protruding pin of the transmission housing and is fixed using two bolts (M6 x 70mm) to a 2mm-thick steel section.

The mounting section is fixed to the fire damper casing using two aluminium rivets (\varnothing 4.8mm). A transmission mechanism is installed between the mounting section and the fire damper casing using four aluminium rivets \varnothing 4.8mm). This mechanism is protected by a plastic sheathing.

A thermal seal is fixed to the fire damper casing using a plastic bracket fixed using a single blind rivet (\varnothing 4.8mm). The thermal seal is fixed to this bracket using two steel screws (\varnothing 3.5mm). The fuse connected to the thermal seal is located on the inside of the fire damper casing.

When switched on, the actuator puts the blade in the open position. An internal torsion spring is compressed at the same time.

If there is a power cut or the fuse stops operating, the internal spring shuts the fire damper.

6. INSTALLATION OF THE TEST SPECIMENS

6.1. INSTALLATION IN A 100MM-THICK AERATED CONCRETE WALL

The fire damper is installed in feed-through in a 100mm-thick aerated concrete wall with a density of 550kg/m³.

The fire damper is positioned in an opening with dimensions (W + 100) x (H + 100) mm. The fire damper is then sealed with standard mortar.

The fire damper can also be sealed using the following types of plaster:

- LAFARGE DELTA (LAFARGE)
- GOLDBAND (KNAUF)
- GYPROC ILPX Plus (BPB)

The fire damper is placed in such a way that the fire damper's mounting lug is flush with the wall surface. The mounting lug can also be bend over and therefore not be involved in sealing the fire damper. In this case, the fire damper is positioned so that the mechanism is flush with the surface of the supporting construction.

The hinge pin of the blade may be horizontally- or vertically-mounted.

6.2. INSTALLATION IN A 110MM-THICK REINFORCED CONCRETE FLOOR

The fire damper is installed in feed-through in a 110mm-thick reinforced concrete floor with a density of 2200kg/m³.

The fire damper is positioned in an opening with dimensions (W + 100) x (H + 100) mm. The fire damper is then sealed with standard mortar.

The fire damper is placed in such a way that the fire damper's mounting lug is flush with the floor surface. The mounting lug can also be bend over and therefore not be involved in sealing the fire damper. In this case, the fire damper is positioned so that the mechanism is flush with the surface of the supporting construction.

6.3. INSTALLATION OF CU-LT FIRE DAMPERS IN A 150MM-THICK AERATED/REINFORCED CONCRETE FLOOR

Fire dampers from the CU-LT range can be sealed using plaster in an aerated/reinforced concrete floor with a minimum thickness of 150mm and a minimum density of 650/2200kg/m³.

The opening for a fire damper has dimensions (W + 100) x (H + 100) mm.

The fire damper can also be sealed using the following types of plaster:

- LAFARGE DELTA (LAFARGE)
- GOLDBAND (KNAUF)
- GYPROC ILPX Plus (BPB)

The fire damper is placed in such a way that the fire damper's mounting lug is flush with the floor surface. The mounting lug can also be bend over and therefore not be involved in sealing the fire damper. In this case, the fire damper is positioned so that the mechanism is flush with the surface of the supporting construction.

6.4. INSTALLATION OF CU-LT FIRE DAMPERS IN A 70MM-THICK PLASTERBOARD PANEL PARTITION

Fire dampers from the CU-LT range can be installed in a plasterboard panel partition made by assembling plasterboard panels with dimensions 660 x 400 x 70mm (w x h x th.) and a density of 850kg/m³ (LAFARGE PLATRES) using plasterboard adhesive (LAFARGE PLATRES). The panels are installed using offset joints, with a half panel offset from one row to another. The joints are approximately 2mm thick.

An opening of dimensions (W + 100) x (h + 100) mm is made by cutting out part of the plasterboard panels. The fire damper is then sealed in the opening with LAFARGE DELTA (LAFARGE PLATRES) plaster. The hinge pin of the blade may be horizontally- or vertically-mounted.

6.5. INSTALLATION OF FIRE DAMPERS IN A BA13, BA18 OR BA25 GYPSUM PLASTERBOARD PARTITION

- Partition

The fire dampers are installed in a "D 98/48"-type partition.

This partition is made using a metal framework fitted with twin-layer facings with special fire-resistant gypsum plasterboard; the partition has an overall thickness of 98mm, with an internal cavity of 48mm filled with stone wool.

- Outer framework

The outer framework is made using 6/10mm-thick galvanised steel MSH 50 rails, fixed to the concrete support frame with steel screws (∅ 6mm) and anchors (∅ 6mm), spaced at intervals of 800mm.

- Central framework

The framework of the partition is made using single, 6/10mm-thick galvanised steel MSV 50 studs, slotted into the upper and lower rails and screwed at the base with a centre-to-centre distance of 600mm. A thermal expansion gap of approximately 5mm is left at the top of each stud.

- Header joist

A header joist designed to allow the fire damper to pass through is made using MSV 50 studs and MSH 50 rails.

The header joist is made of:

- A stud added to the central framework of the partition spaced (L + 65) mm from the stud belonging to the central framework and acting as a second support stud for the weight of the fire damper itself;
- An R 48 horizontal rail, sheared and bent, and installed perpendicular to the additional studs at the top and bottom and spaced (H + 65) mm apart from one another.
- For fire dampers with a length (L + 65) mm greater than 600mm, the stud belonging to the central framework is interrupted for the installation of the header joist.

The various elements are fixed together using screws (\varnothing 3.5mm).

- Facings

The partition is made using 12.5mm-thick GYPROC Rf-type plasterboards with a density of 750kg/m³. The facings can also be made using BA18 or BA25 plasterboard panels provided the reports (*procès-verbaux*) associated with the partitions made using these panels show that they meet the EI 120 fire resistance criterion.

For BA 13 panels, the plasterboard is installed with the vertical joints of one facing offset in relation to the other within the same facing and also between the inner surfaces of both facings.

The vertical joints of the plasterboards are perpendicular to the studs. The plasterboards are fixed to the framework with 212/25-type self-drilling screws spaced at intervals of 500mm for the first layer and 212/35-type screws at intervals of 300mm for the second layer.

The visible joints between the plasterboards and the screeds with concrete frame are treated using the JOINTFILLER filler + jointing tape technique. The screw heads are also concealed with the same filler.

The cavity between the plasterboards is filled with ROCKFIT 431-type stone wool with a density of 33kg/m³.

- Sealing around the fire damper

The space between the tunnel of the fire damper and the wall is approximately 30mm. A 12.5mm-thick strip of plaster reinforced with RINOFLAM-type glass wool, with a density of 850kg/m³, wrapped around the fire damper, is fixed to the wall every 250mm using self-drilling steel M6 screws above this space. All the joints between the plasterboard are covered with BPB GYPROC Jointfiller 45-type filler.

The screws are also covered with the same type of filler.

6.6. INSTALLATION OF THE OFFSET FIRE DAMPERS

For the offset installation of 100mm-thick aerated concrete wall with a duct made using sheet metal and protected by GEOFLAM 45-type plates:

The CU-LT fire damper was installed offset, inside or outside the furnace, on a galvanised steel sheet service duct.

The length of this duct is not specified. If the duct length is greater than 1m, a supporting system will be implemented as described above, at intervals of 1m, as well as additional support level with the fire damper.

The fire damper was fixed to the duct using 10 x 118 x 20mm bolts.
See drawing in the appendix.

- Protection of the duct and fire damper.

The service duct was covered with 45mm-thick staff plates, reference GEOFLAM F, fixed together using glue and packing. The fire damper casing was therefore also protected over a length of 120mm. The GEOFLAM F staff plate protection was introduced between the fire damper and the wall. It stopped 15mm from the wall. The free space between the wall and the staff plate protection was filled by packing (a mix of plaster and fibrous material).

- Seal

The opening, with dimensions (W + 100) x (H + 100) mm and made in the 100mm-thick aerated concrete wall, was filled with standard mortar (reference CEM II/B-V-32.5N manufactured by CBR-Heidelberg)

- Duct support system

The hangers were composed of 8mm diameter threaded rods and supporting rails with dimensions of 25 x 25 x 2mm and 1m long. A distance of approximately 25mm was kept between the threaded rods and the vertical sides of the duct.

The threaded rods were protected by staff half-shells (Ø 90mm) and held together using adhesive and packing. The crossmember was protected with a "U"-shaped protective section in plaster (100 x 60mm), glued to the underside of the duct with PLACOL (PLACO SAINT-GOBAIN) or GEOCOL (GEOSTAFF) type adhesive plaster.

For the offset installation of 100mm-thick aerated concrete wall with a duct made using GEOFLAM 45-type plates:

The CU-LT fire damper was installed offset, inside or outside the furnace, on a GEOFLAM 45-type plate service duct.

The length of this duct is not specified. If the duct length is greater than 1m, a supporting system will be implemented as described above, at intervals of 1m, as well as additional support level with the fire damper.

- Protection of the duct and fire damper

The service duct was made with 45mm-thick staff plates, reference GEOFLAM F, fixed together using glue and packing. The fire damper casing was therefore also protected over a length of 120mm. The GEOFLAM F staff plate protection was introduced between the fire damper and the wall. It stopped 15mm from the wall. The free space between the wall and the staff plate protection was filled by packing (a mix of plaster and fibrous material).

- Seal

The opening, with dimensions (W + 100) x (H + 100) mm and made in the 100mm-thick aerated concrete wall, was filled with standard mortar (reference CEM II/B-V-32.5N manufactured by CBR-Heidelberg)

- Duct support system

The hangers were composed of 8mm diameter threaded rods and supporting rails with dimensions of 25 x 25 x 2mm and 1m long. A distance of approximately 25mm was kept between the threaded rods and the vertical sides of the duct.

The threaded rods were protected by staff half-shells (Ø 90mm) and held together using adhesive and packing.

The crossmember was protected with a "U"-shaped protective section in plaster (100 x 60mm), glued to the underside of the duct with PLACOL (PLACO SAINT-GOBAIN) or GEOCOL (GEOSTAFF) type adhesive plaster.

For the offset installation of a 100mm-thick aerated concrete wall or a 100mm-thick gypsum plasterboard partition with a duct made using sheet metal and protected by stone wool panels for EI 60 performance:

The CU-LT fire damper + IFW Kit was installed offset, inside or outside the furnace, on a galvanised steel sheet service duct.

The length of this duct is not specified. If the duct length is greater than 1500mm, a supporting system will be implemented as described above, at intervals of 1500mm, as well as additional support level with the fire damper.

The fire damper was fixed to the duct using 10 x 118 x 20mm bolts.

See drawing in the appendix.

- Protection of the duct and fire damper

The service duct was covered with 60mm-thick Promastop CB 60-type stone wool panels fixed to the duct using screws (Ø 5 x 90mm) and washers (M6 x 44mm). The fire damper casing was therefore also protected over a length of 150mm.

The joints between the panels, the screws and the support washers were covered with Promastop E-type coating.

- Seal

The opening, with dimensions (W + 600) x (H + 600) mm and made in the 100mm-thick aerated concrete wall or a 100mm-thick gypsum plasterboard partition, was filled with:

- o One layer of 60mm-thick Promastop CB60-type stone wool panels covered with Promastop E-type coating on both sides.

The Promastop E filler was also applied to the joints between the stone wool panels and on the joints between the stone wool panels and the supporting construction (the surface was already pre-coated).

- Duct support system

The hangers were composed of 8mm diameter threaded rods and supporting rails with dimensions of 35 x 35 x 2mm and 1m long. A distance of approximately 25mm was kept between the threaded rods and the vertical sides of the stone wool inner panel.

The threaded rods and the rail were not protected.

The hangers are located at the joint between the duct and the fire damper, approximately 1800mm from the wall.

For the offset installation of a 100mm-thick aerated concrete wall or a 100mm-thick gypsum plasterboard partition with a duct made using sheet metal and protected by stone wool panels for EI 90 performance:

The CU-LT fire damper + IFW Kit was installed offset, inside or outside the furnace, on a galvanised steel sheet service duct.

The length of this duct is not specified. If the duct length is greater than 1500mm, a supporting system will be implemented as described above, at intervals of 1500mm, as well as additional support level with the fire damper.

The fire damper was fixed to the duct using 10 x 118 x 20mm bolts.
See drawing in the appendix.

- Protection of the duct and fire damper

The service duct was covered with two layers of 50mm-thick Promastop CB 60-type stone wool panels or one layer of 80mm-thick Promastop CB 80-type stone wool panels fixed to the duct using screws (\varnothing 5 x 120mm) and washers (M6 x 44mm). The fire damper casing was therefore also protected over a length of 150mm.

The joints between the panels, the screws and the support washers were covered with Promastop E-type coating.

- Seal

The opening, with dimensions (W + 600) x (H + 600) mm and made in the 100mm-thick aerated concrete wall or a 100mm-thick gypsum plasterboard partition, was filled with:

- o Two layers of 50mm-thick Promastop CB50-type stone wool panels covered with Promastop E-type coating on one side for 90 minutes.
- o One layer of 80mm-thick Promastop CB80-type stone wool panels covered with Promastop E-type coating on both sides for 90 minutes.

The Promastop E filler was also applied to the joints between the stone wool panels and on the joints between the stone wool panels and the supporting construction (the surface was already pre-coated).

- Duct support system

The hangers were composed of 8mm diameter threaded rods and supporting rails with dimensions of 50 x 38 x 5mm and 1m long. A distance of approximately 25mm was kept between the threaded rods and the vertical sides of the stone wool inner panel.

The threaded rods and the rail were not protected.

The hangers are located at the joint between the duct and the fire damper, approximately 1800mm from the wall.

7. FIRE RESISTANCE CLASSIFICATIONS

7.1. CLASSIFICATION REFERENCE

This classification procedure was conducted in accordance with section 7.2.4 of the standard EN 13501-4.

7.2. CLASSIFICATIONS

The elements are classified according to the following combinations of performance parameters and classes for the following supporting constructions.

The dimensional range* covered by the performances stated below is as follows:

	200	250	300	350	400	450	500	550	600	650	700	750	800
100													
150													
200													
250													
300													
350													
400													
450													
500													
550													
600													

* Interval of 50mm provided for information only.

- Fire dampers installed with IFW installation kit in a light partition made using 98/48 type A (EN520) gypsum plasterboard panels.

No other classification is authorised.

E	I		t		ve	-	ho	-	i	↔	o	-	S
E	I		60		ve	-		-	i	↔	o	-	S

- Fire dampers installed in:
 - A 100mm-thick aerated concrete wall with mortar seal
 - A 110mm-thick reinforced concrete floor with mortar seal
 - Light partition made using 98/48 type F (EN520) gypsum plasterboard panels

No other classification is authorised.

E	I		t		ve	-	ho	-	i	↔	o	-	S
E	I		90		ve	-	ho	-	i	↔	o	-	S

- Fire dampers installed in:
 - A 100mm-thick aerated concrete wall with plaster seal
 - A 150mm-thick reinforced concrete floor with plaster seal
 - A 150mm-thick aerated concrete floor with plaster seal
 - A 70mm-thick plasterboard panel partition

No other classification is authorised.

E	I		t		ve	-	ho	-	i	↔	o	-	S
E	I		120		ve	-	ho	-	i	↔	o	-	S

- Offset fire dampers using a sheet metal duct protected by stone wool:

The maximum approved operating vacuum pressure in this case is -300Pa.

Where seal is made using PROMASTOP CB 80 panels with th. = 60mm + with IFW installation kit

E	I	-	t		ve	ho	i	<->	o	S
E	I		60		ve		i	<->	o	S

Where seal is made using PROMASTOP CB 80 panels with th. = 1 x 80 or 2 x CB 50 th. = 100mm + with IFW installation kit

E	I	-	t		ve	ho	i	<->	o	S
E	I		90		Ve		i	<->	o	S

- Offset fire dampers using a sheet metal duct protected by GEOFLAM F 45 plates:

The maximum approved operating vacuum pressure in this case is -500Pa.

E	I	-	t		ve	ho	i	<->	o	S
E	I		120		Ve		i	<->	o	S

- Offset fire dampers using a duct made of GEOFLAM F 45 plates:

The maximum approved operating vacuum pressure in this case is -500Pa.

E	I	-	t		ve	ho	i	<->	o	S
E	I		120		ve		i	<->	o	S

The above performances of the elements are valid for heating as described in section 5.1.1 of the European standard EN 1363-1.

8. FIELD OF APPLICATION OF THE RESULTS

8.1. GENERAL POINTS

The requirements related to the field of application of all the fire dampers tested in accordance with EN 1366-2 apply, as well as the following items.

8.2. DIMENSIONS OF THE FIRE DAMPER

In accordance with section 13.1 of the standard EN 1366-2, the classifications indicated in section 7.2 of this classification report are valid for all fire dampers of the same type (including all the side reports), provided the maximum flow cross-section dimensions do not exceed 800 x 600mm and that the minimum flow cross-section dimensions are not less than 200 x 100mm.

8.3. SEPARATION BETWEEN FIRE DAMPERS AND BETWEEN FIRE DAMPERS AND CONSTRUCTION ELEMENTS

In accordance with section 13.5 of the standard EN 1366-2, the fire classifications indicated in section 7.2 of this classification report apply, in practice, with a minimum spacing:

- a) of 200mm between fire dampers installed in separate ducts;
- b) of 75mm between the fire damper and a construction element (wall or boards).

8.4. SUPPORTING CONSTRUCTIONS

In accordance with section 13.6.1 of the standard EN 1366-2, the classifications indicated in section 7.2 of this classification report apply only to fire dampers installed in feed-through in an aerated concrete wall with a minimum thickness of 100mm and a minimum density of 550kg/m³, built into a reinforced concrete wall with a minimum thickness of 110/150mm and a minimum density of 2200kg/m³ or installed in feed-through or offset in a supporting construction of the same type as the standardized flexible supporting construction used in the test, with equal or greater fire resistance properties (greater thickness, higher density or more layers of plasterboard, as appropriate).

The test result may also apply to hollow masonry blocks or slabs possessing a fire resistance time that is equal to or greater than the one stated for the installation of the fire damper.

No modifications may be applied to the dimensions expressed above (see section 10.3.1) and no modifications may be made to the structure of the element without the prior issue of a classification extension by the laboratory.

Issued in Maizières-lès-Metz, 16 June 2016

A handwritten signature in black ink, appearing to read "Fenucci", with a horizontal line underneath.

Mathieu Fenucci
Project Director

APPENDIX 1 - Figure 1

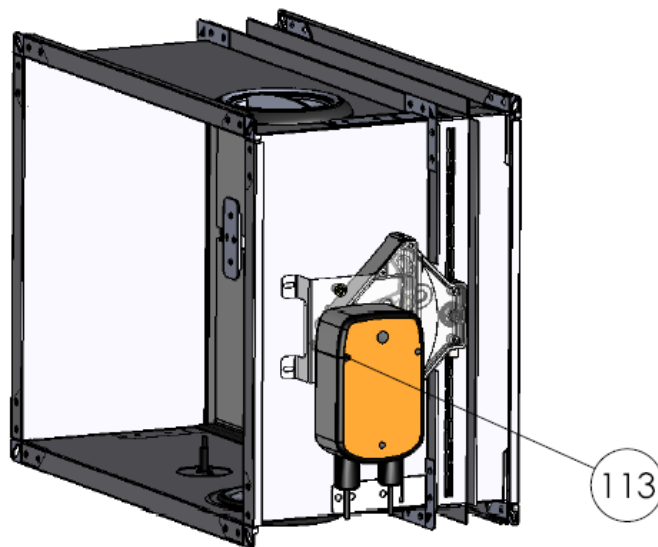
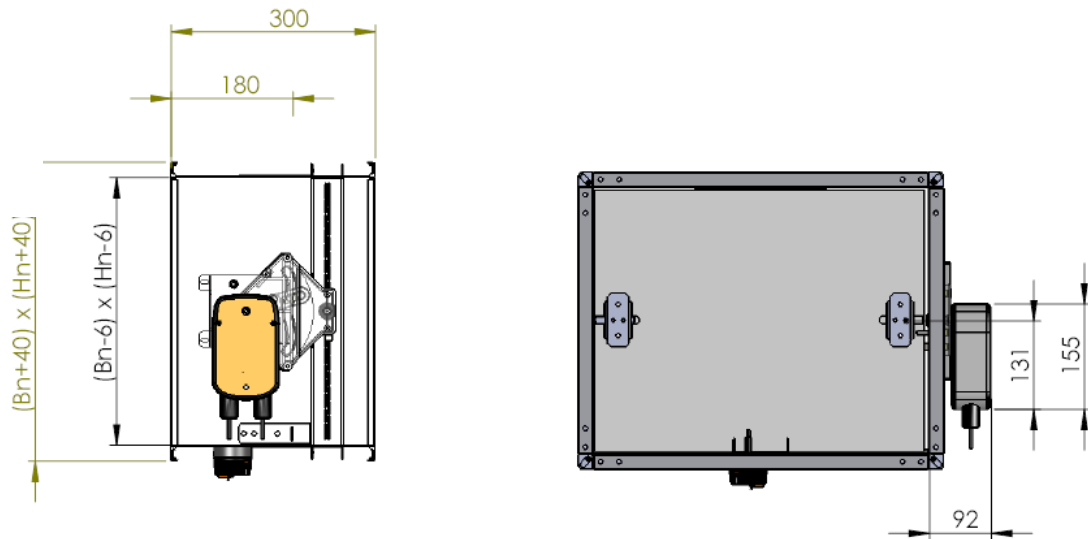

APPENDIX 1 - Figure 2

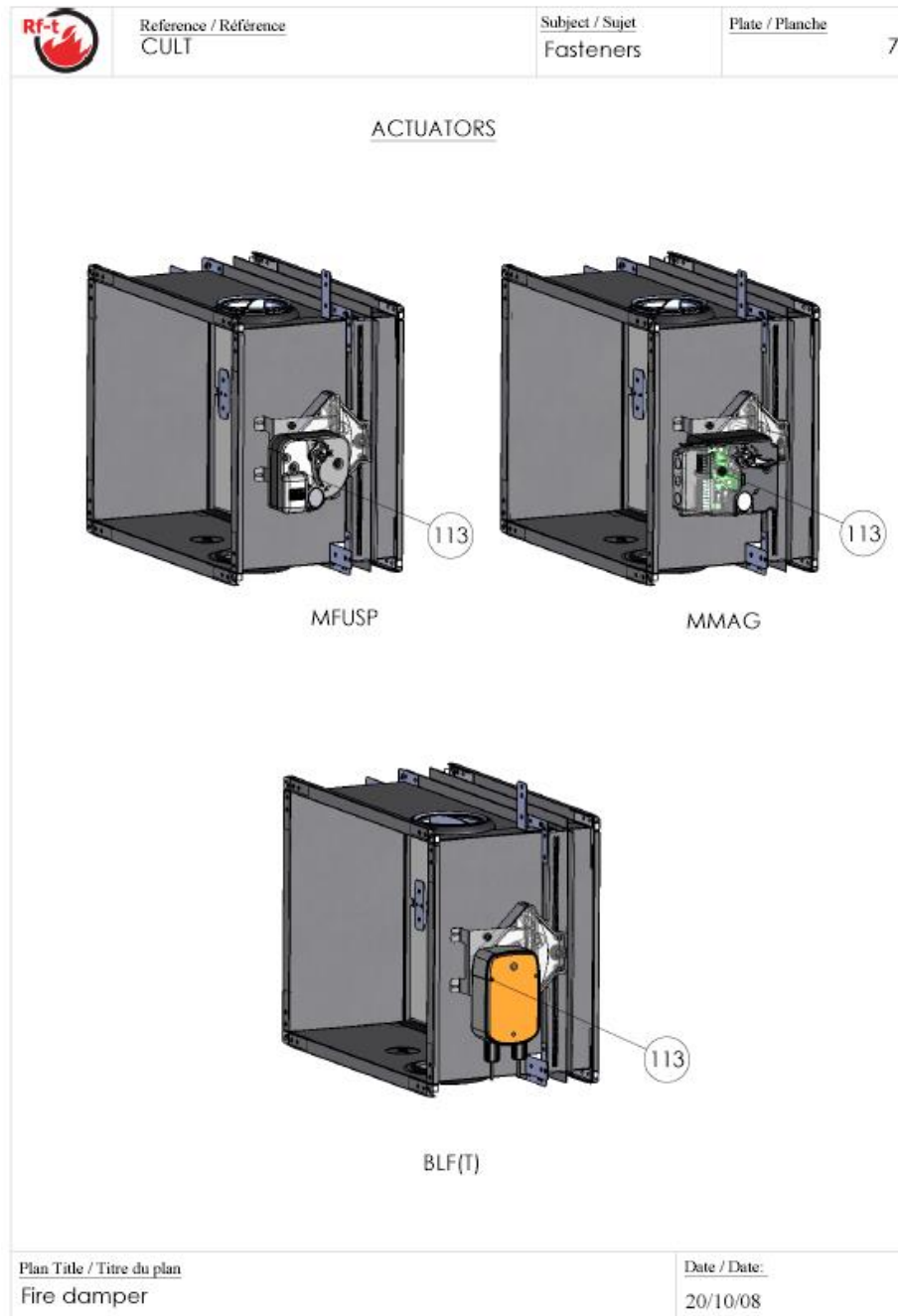

APPENDIX 1 - Figure 3

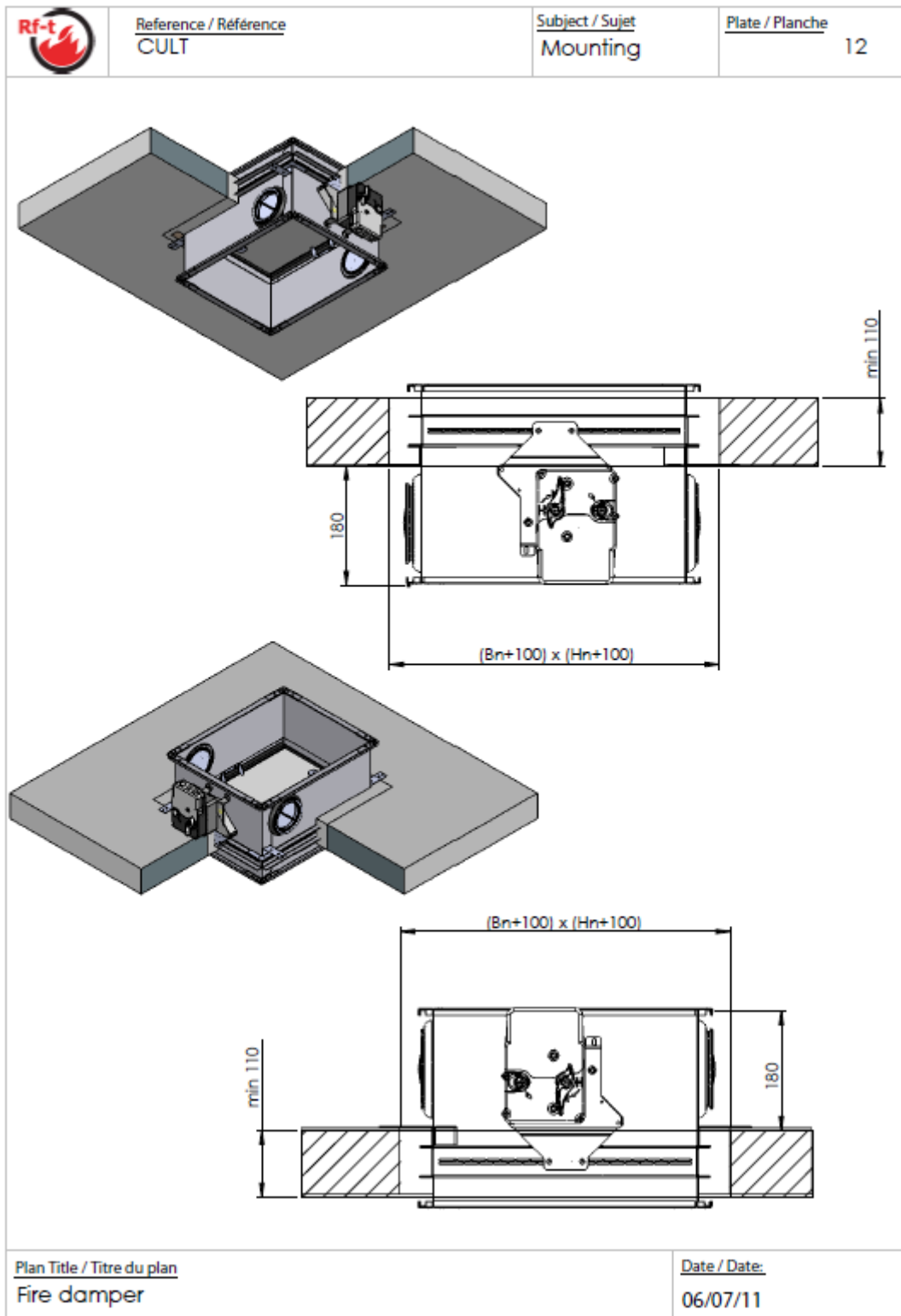

APPENDIX 1 - Figure 4

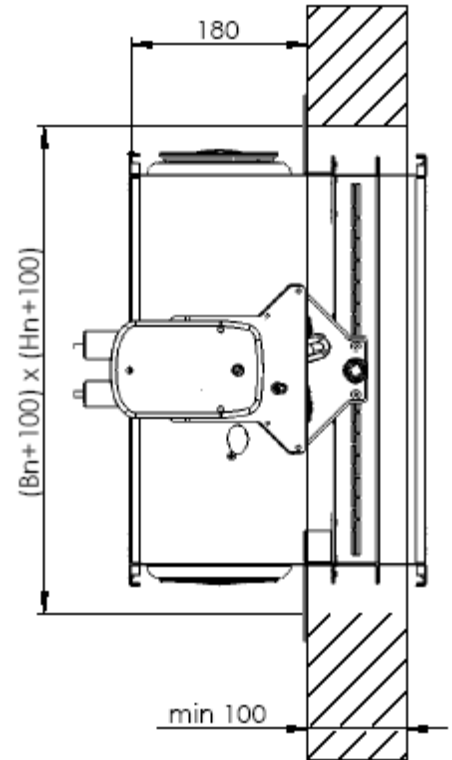
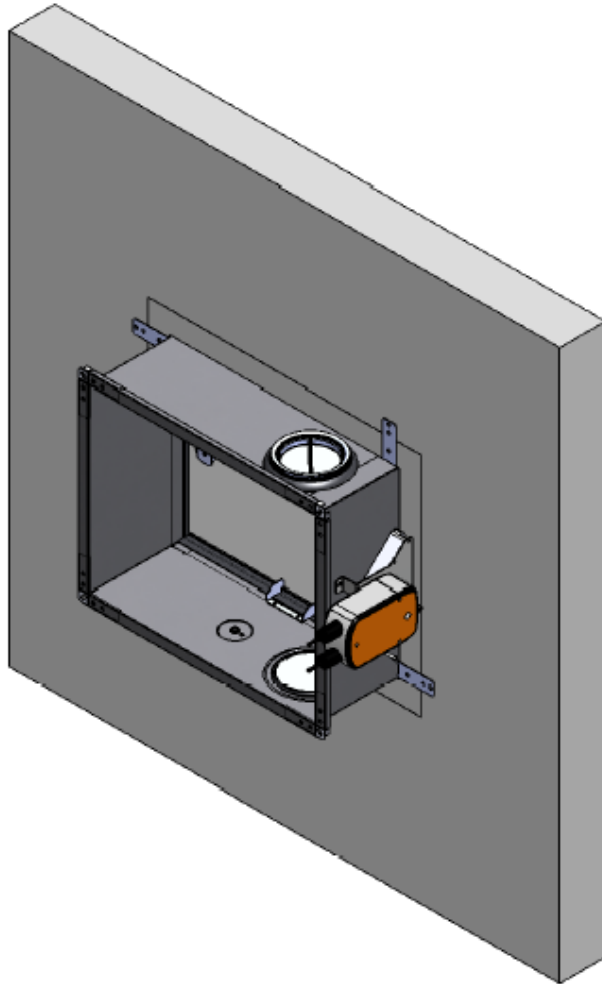

APPENDIX 1 - Figure 5

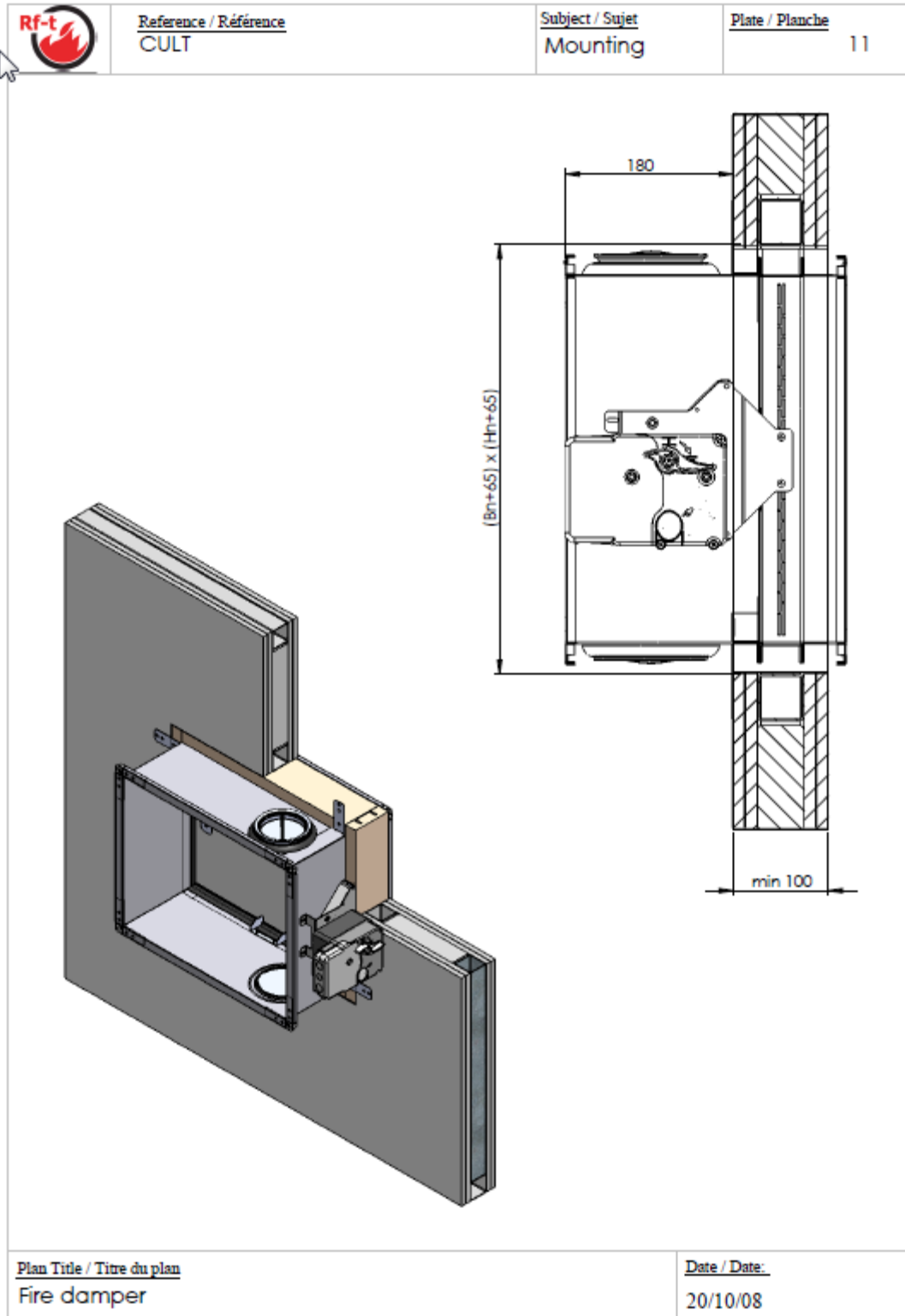

APPENDIX 1 - Figure 6

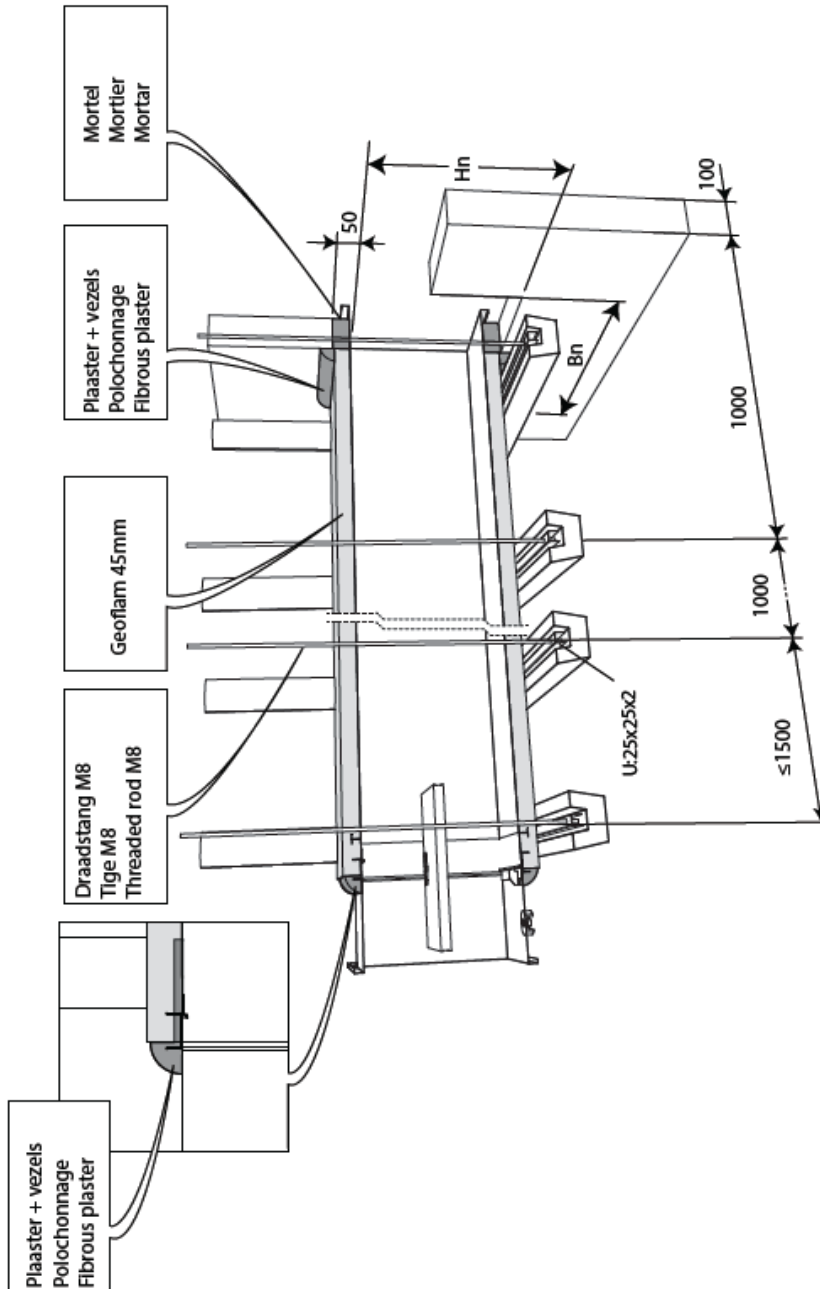

APPENDIX 1 - Figure 7

