



CLASSIFICATION REPORT no. 07 - A - 057 - Revision 3

According to standards EN 15650: 2010 and EN 13501-3: 2007

Reference Laboratory Evaluation

07 - A - 057 - Revision 1

Regarding

A range of "CR60" type fire dampers

- Installed in feed-through in wall or floor slab
- Installed offset from a cellular concrete structure or 98/48-type plasterboard (gypsum) partition by:
 - A sheet metal duct protected by stone wool
- Installed offset from a cellular concrete structure by:
 - A sheet metal duct protected by GEOFLAM 45-type panels
 - Or a duct created by assembly of GEOFLAM 45-type panels

Operating vacuum pressure: - 500Pa

Applicant

RF TECHNOLOGIES
Lange Ambachtstraat, 40

B - 9860 OOSTERZELE

This classification report supersedes the classification report no. 07 - A - 057 - Revision 2.

TRACKED CHANGES

Revision index	Date	Modification	Realized by
2	14/09/2016	- integration of fitting collar 1S	CSC
3	08/06/2017	<ul style="list-style-type: none">- Validation of remote installation with wool HILTI-CFS-CT- Validation of installation 0 distance- Validation of installation in a non-rigid wall in type F plasterboard- Validation of damper sealing with plaster- Validation of sealing of dampers using stone wool and plasterboard	RST

1. INTRODUCTION

This classification report defines the classification assigned to a range of "CR60"-type fire dampers in accordance with the procedures set out in the standard EN 13501-3: 2007 "Fire classification of construction products and building elements – Part 3: Classification using data from fire resistance tests, on products and elements used in building service installations: fire resisting ducts and fire dampers" and in the standard EN 15650: 2010 "Ventilation for buildings. Fire dampers".

2. BODY

EFFECTIS France
Voie Romaine
F – 57280 MAIZIERES-LES-METZ

Notified body: 1812

3. APPLICANT

RF TECHNOLOGIES
Lange Ambachtstraat, 40
B - 9860 OOSTERZELE

4. REFERENCE AND ORIGIN OF THE TEST SPECIMENS

Reference: CR60

Origin: RF TECHNOLOGIES
Lange Ambachtstraat, 40
B - 9860 OOSTERZELE

5. OVERALL PRINCIPLE

5.1. TYPE OF FUNCTION

The "CR60"-type damper is defined as a "fire damper". Its function is to resist fire as regards fire integrity, thermal insulation and leakage flow rates.

5.2. GENERAL POINTS

Each fire damper is composed of a tunnel, within which a horizontally- or vertically-mounted mobile blade pivots using an external mechanism and a transmission.

Approved fire dampers have flow cross-section dimensions of between Ø 100 mm and Ø 315 mm.

5.3. DETAILED DESCRIPTION OF THE ELEMENTS

5.3.1. Fire damper casing

The fire damper casing is composed of a galvanised steel duct with \varnothing (D-1) mm, 0.8 mm thick and 345 mm long.

Level with the fire damper blade, the perimeter of the casing is perforated with 40 x 3 mm holes, at 2.5 mm intervals over a width of 19.5 mm.

On the inside, the perforations are completely covered by graphite, self-adhesive, intumescent tape of dimensions 35 x 1.5 mm. A strip of self-adhesive PVC tape is placed on the outside of the fire damper casing.

Halfway up, the fire damper casing has two openings (\varnothing 9 and \varnothing 16 mm), which allow the hinge pin of the fire damper blade to pass through, and three openings (\varnothing 5.3 mm), which are used to fix the transmission housing using aluminium rivets (\varnothing 4.8 mm).

5.3.2. Blade

The fire damper blade is composed of a 20 mm-thick Promatect H panel fitted with a rubber seal on its entire circumference.

Two aluminium hinge pin brackets, with cross section dimensions of 30 x 18 mm, are fixed on the blade using two aluminium rivets (\varnothing x 4.8 mm). The blade pivots on a square steel hinge pin, with cross section dimensions of 5 x 5 mm. The pin rests on two POM (polyoxymethylene) bearings (\varnothing 15 x 9 mm), fitted in the wall of the fire damper casing.

5.3.3. Mechanism

The actuator is connected to the protruding pin of the transmission housing and is fixed using two bolts (M6 x 70 mm) to a steel section which is in turn connected to the fire damper casing.

The control mechanism is fully installed on the outside of the fire damper and is composed of the following elements:

- An actuator (9)
- A fixing profile (10)
- A transmission mechanism (11)
- A fusible link (12)

The actuator is fixed to the fire damper casing using two aluminium rivets (\varnothing 4.8 mm) via a steel mounting section (10). A transmission mechanism (11) is installed between the mounting section and the fire damper casing. This mechanism is protected by a plastic housing (13). The transmission mechanism is connected to the fire damper's hinge pin (7).

A fusible link (12) is fixed perpendicularly to the position of the actuator on the fire damper casing using a steel corner bracket (14). A plastic housing (15) is fitted to this corner bracket and fixed to the fire damper casing using a single blind rivet through the corner bracket. The fusible link is fixed to the corner bracket using two steel screws (\varnothing 3.5 mm). The fuse, which is connected to the fusible link, is located on the inside of the fire damper casing.

When under power, the actuator puts the blade in the open position. An internal torsion spring is tensioned at the same time.

If the power is cut or the fuse functions, the internal spring shuts the fire damper.

5.3.4. Kit / option 1S

Fire dampers type CR60 can be equipped with a fixing collar 1S composed of two glass fiber reinforced plaster shells (manufacturer: GEOSTAFF, material: MC6 of BPB PLACO) (see drawings in appendix). The two shells are fixed together with two layers of self-adhesive PVC strip of width 50 mm.

The perimeter of this plaster reinforcement is also equipped with an intumescent graphite strip type EX147 (RFT) thickness of 2 mm and width of 30 mm.

Fire integrity between collar and fire damper is made with foam EPDM of section dimensions 8 x 5 mm.

Kit 1S is settled against the supporting structure and fixed to it by 6 screws \varnothing 5 x 70 mm for a wall mounting and by 6 screws \varnothing 6 x 120 mm for a ceiling mounting.

6. INSTALLATION OF THE TEST SPECIMENS

The classification obtained for a standard installation in the different construction elements and their respective sealing remains valid for dampers installed with an axis angle from horizontal up to 45°, with a spacing:

- of 30 to 200 mm between fire dampers installed in separate ducts;
- of 30 to 75 mm between the fire damper and a construction element (wall or floor).

Sealing between dampers, or between a single damper and supporting structure (wall or floor) is provided by a maximum of eight layers (3 layers on each side of the wall and 2 layers in the opening) of stone wool of total width 400 mm (stone wool having the following characteristics: layer thickness 50 mm, density 150 kg/m³, thermal conductivity $\lambda= 0.041$ W/mK at 50 ° C, water vapour absorption 0.02%, Euroclass A1)

6.1. INSTALLATION IN A 100 MM-THICK CELLULAR CONCRETE WALL

The fire damper is installed in feed-through in a 100 mm-thick wall with a density of 550 kg/m³.

The fire damper is positioned in an opening with dimensions ($\varnothing + 80$) mm. The fire damper is then sealed with standard mortar.

It can be positioned with a horizontally- or vertically-mounted blade.

6.2. INSTALLATION IN A 100 MM-THICK CELLULAR/REINFORCED CONCRETE FLOOR

The fire damper is installed in feed-through in a 100 mm-thick cellular/reinforced concrete wall with a density of 650/2200 kg/m³.

The fire damper is positioned in an opening with dimensions ($\varnothing + 80$) mm. The fire damper is then sealed with standard mortar.

6.3. INSTALLATION IN A PLASTERBOARD (GYPSUM) PARTITION

6.3.1. Partition

The fire dampers are installed in a "D 98/48" partition.

This partition is made using a metal framework fitted with double-layer facings of type A or F paper-backed gypsum plasterboard (EN520); the partition has an overall thickness of 98 mm, with an internal cavity of 48 mm filled with stone wool.

6.3.2. Outer framework

The outer framework is made using 6/10 mm-thick galvanised steel MSH 50 rails, fixed to the concrete support frame with steel screws \varnothing 6 mm and plugs \varnothing 6 mm, spaced at intervals of 800 mm.

6.3.3. Central framework

The framework of the partition is made using single, 6/10 mm-thick galvanised steel MSV 50 studs, slotted into the upper and lower rails and screwed to the base with a centre-to-centre distance of 600 mm. A thermal expansion gap of approximately 5 mm is left at the top of each stud.

6.3.4. Header joist

A header joist designed to accept passage of the fire damper is made using MSV 50 studs and MSH 50 rails.

The header joist is made of:

- Two studs (A) added to the central framework of the partition at ($\varnothing + 50$) mm [or ($\varnothing + 80$) mm, for plaster sealing] acting as supporting uprights to carry the weight of the damper;
- An R 48 (B) horizontal rail, cut and bent, and installed perpendicular to the additional studs at the top and bottom and separated by ($\varnothing + 50$) mm [or ($\varnothing + 80$) mm, for plaster sealing].

The various elements are fixed together using screws (\varnothing 3.5 mm).

The fire damper can be positioned with a horizontally- or vertically-mounted blade.

6.3.5. Facings

Solution 1:

The partition is made using 12.5 mm-thick BPB GYPROC ABA -type plasterboards with a density of 708 kg/m³.

For BA 13, the plasterboard is installed with the vertical joints of one facing offset in relation to the other within the same facing and also between the inner surfaces of both facings.

The vertical joints of the plasterboards are aligned with the studs. The plasterboards are fixed to the framework with 212/25-type self-drilling screws spaced at intervals of 500 mm for the first layer and 212/35-type screws at intervals of 300 mm for the second layer.

The visible joints between the plasterboards and return angles and the concrete structure are treated with JOINTFILLER coating + sealing tape. The screw heads are also covered with the same coating.

The cavity between the plasterboards is filled with ROCKFIT 431-type stone wool with a density of 33 kg/m³.

Solution 2:

This double facing can be replaced by 1 x BA 25 / BA 18-type single-layer facing.

The facings are made using a single layer of BA 25 / BA 18 plasterboard. The plasterboards have a maximum width of 600 mm.

The plasterboards are fixed onto all of the steel sheet studs using TTPC 35 screws spaced at average intervals of 250 mm.

The joints between the plasterboards are treated with plaster coating, into which a 52 mm-wide strip of micro-perforated jointing tape is smoothed.

The return angles and screw heads are treated with plaster coating.

The space between the fire damper tunnel and the wall is approximately 30 mm. A 100 mm wide stub of plasterboard of bulk density 750 kg/m^3 25 mm thick, and of the same type as the facing, fixed around the full periphery of the damper, is fixed to the wall every 250 mm using steel self-drilling M6 screws above this space.

This stub is of the same type as the facing. However, it may be replaced by a 12.5 mm-thick stub.

The space between the two stubs and between the fire damper and the wall is filled with stone wool with a density of 40 kg/m^3 .

Solution 3:

This double facing can be replaced by a double facing of type 2 x BA 13 type F.

The facings are made using a double layer of BA 13 plasterboard. The plasterboards have a maximum width of 600 mm.

The plasterboards are fixed onto all of the steel sheet studs using TTPC 35 screws spaced at average intervals of 250 mm.

The joints between the plasterboards are treated with plaster coating, into which a 52 mm-wide strip of micro-perforated jointing tape is smoothed.

The return angles and screw heads are treated with plaster coating.

6.3.6. Sealing around the fire damper

Solution 1:

The space between the tunnel of the fire damper and the wall is approximately 30 mm. A plasterboard stub, with a density of 750 kg/m^3 , thickness of 12.5 mm and width of 100 mm, the same type as the facing and fixed to the entire periphery of the fire damper, is fixed to the wall every 250 mm using self-drilling, steel M6 screws above this space.

The space between the two stubs and between the fire damper and the wall is filled with stone wool with a density of 40 kg/m^3 .

All the joints between the plasterboard are covered with BPB GYPROC Jointfiller 45-type filler.

The screws are also covered with the same type of coating.

Solution 2:

The joint between the CR60 and CR120 fire damper casing and the wall is plugged with stone wool with a density of 60 kg/m³. The clearance between the tunnel and the wall is approximately 25 mm. On the facing side, the free space between the fire dampers and the wall, previously filled with stone wool, is covered with a layer of PREGYLYS (LAFARGE) type filler, spread across the fire damper casing and the supporting construction over a minimum length of 50 mm, so as to ensure the two surfaces are perfectly sealed.

Solution 3:

On both the fire side and side away from fire, the gap between the damper tunnel and the cut-out is plugged with standard plaster.

6.4. INSTALLATION OF THE OFFSET FIRE DAMPERS

The fire dampers described below may also be offset using an identical supporting construction to those described in sections 6.1 and 6.3 of this document.

- **For the offset installation of a cellular concrete wall with a sheet metal duct and protected by panels of GEOFLAM 45, GEOFLAM F LIGHT 35 or GEOTEC S 45:**

The CR 60 fire damper is installed offset, inside or outside the furnace, on a galvanised steel sheet through duct.

The length of this duct is not specified. If the length of the duct exceeds 1 m, support will be implemented as described below at 1 m intervals together with additional support for the damper.

The fire damper is fixed to the duct using four screws (Ø 4.2 x 13 mm).

- Protection of the duct and fire damper:

GEOFLAM 45:

The service duct is protected by a rectangular duct made of fibrous plaster panels, reference GEOFLAM F and 45 mm thick, assembled together around the duct using Placol 2h (PLACO) adhesive. This is only done for the duct located inside the furnace (the part located outside the furnace is not protected). The GEOFLAM F fibrous plaster protection is introduced between the fire damper and the wall. It stops 20 mm from the wall. The free space between the wall and fibrous plaster protection is filled by stuffing with caulking (mixture of plaster and fibre). The plaster used is reference Molda® Duo (PLACO SAINT GOBAIN).

The outer cross-section dimensions of this duct are (Ø + 125) x (Ø + 125) mm (w x h).

The fire damper casing is therefore also protected over a length of 171 mm.

The joints between the panels are treated with caulking (mixture of plaster and fibrous material) inside the fibrous plaster protection. The plaster used is reference Molda® Duo (PLACO SAINT GOBAIN).

GEOFLAM F LIGHT 35 or GEOTEC S 45:

The through duct comprises fibrous plasterboard panels of 35 mm thick Geoflam F LIGHT or 45 mm thick GEOTEC S fixed together with glue and caulking. The damper body is also protected over a length of 120 mm.

The GEOFLAM F LIGHT or GEOTEC S fibrous plaster protection is introduced between the fire damper and the wall. It stops 15 mm from the wall. The free space between the wall and fibrous plaster protection is filled by stuffing with caulking (mixture of plaster and fibre).

- Sealing:

The opening, with dimensions ($\varnothing + 80$) x ($\varnothing + 80$) mm and made in the cellular concrete wall (th. 100 mm), is filled with mortar, thus enabling the duct to be sealed. The mortar used consists of sand, water and cement reference CEM II / B-V-32.5N manufactured by CBR-Heidelberg.

- Duct support system:

The fibrous plaster protection is supported by two rows of hangers 1000 mm apart. The first hanger is fixed 580 mm from the cellular concrete wall. The hangers are composed of 8 mm diameter threaded rods and 2 mm-thick U-shaped steel supporting rails with dimensions of 25 x 25 x 2 mm and 510 mm long. A distance of approximately 25 mm is kept between the threaded rods and the vertical sides of the duct.

The threaded rods are protected by fibrous plaster half-shells ($\varnothing 90$ mm) fixed together using adhesive and caulking.

The crossmember is protected with a "U"-shaped protective section in plaster (100 x 60 mm), glued to the underside of the duct with PLACOL (PLACO SAINT-GOBAIN) or GEOCOL (GEOSTAFF) adhesive plaster.

- **For the offset installation of a cellular concrete wall with a duct in panels of GEOFLAM 45, GEOFLAM F LIGHT 35 or GEOTEC S 45:**

The CR 60 fire damper is installed offset, inside or outside the furnace, on a through duct made of panels of GEOFLAM F 45, GEOFLAM F LIGHT 35 or GEOTEC S 45.

The length of this duct is not specified. If the length of the duct exceeds 1 m, support will be implemented as described below at 1 m intervals together with additional support for the damper.

- Protection of the duct and fire damper:

GEOFLAM 45:

The through duct is composed of 45 mm-thick fibrous plaster panels, reference GEOFLAM F, fixed together using Placol 2H adhesive. The fire damper casing is therefore also protected over a length of 171 mm. The GEOFLAM F fibrous plaster protection is introduced between the fire damper and the wall. It stops 20 mm from the wall. The free space between the wall and fibrous plaster protection is filled by stuffing with caulking (mixture of plaster and fibre). The plaster used is reference Molda® Duo (PLACO SAINT GOBAIN).

GEOFLAM F LIGHT 35 or GEOTEC S 45:

The through duct comprises fibrous plasterboard panels of 35 mm thick Geoflam F LIGHT or 45 mm thick GEOTEC S fixed together with glue and caulking. The damper body is also protected over a length of 120 mm.

The GEOFLAM F LIGHT or GEOTEC S fibrous plaster protection is introduced between the fire damper and the wall. It stops 15 mm from the wall. The free space between the wall and fibrous plaster protection is filled by stuffing with caulking (mixture of plaster and fibre).

- Sealing:

The opening, with dimensions ($\varnothing + 80$) x ($\varnothing + 80$) mm and made in the cellular concrete wall (th. 100 mm) is filled with standard mortar (reference CEM II/B-V-32,5N produced by CBR-Heidelberg).

- Duct support system:

The fibrous plaster protection is supported by two rows of hangers 1000 mm apart. The first hanger is fixed 580 mm from the cellular concrete wall. The hangers are composed of 8 mm diameter threaded rods and 2

mm-thick U-shaped steel supporting rails with dimensions of 25 x 25 x 2 mm and 510 mm long. A distance of approximately 25 mm is kept between the threaded rods and the vertical sides of the duct.

The threaded rods are protected by fibrous plaster half-shells (\varnothing 90 mm) fixed together using adhesive and caulking.

The crossmember is protected with a "U"-shaped protective section in plaster (100 x 60 mm), glued to the underside of the duct with PLACOL (PLACO SAINT-GOBAIN) or GEOCOL (GEOSTAFF) adhesive plaster.

- **For the offset installation of a cellular concrete wall or a gypsum plasterboard partition using a duct in sheet metal and protected by panels of stone wool for EI 90 performance:**

The CR 60 fire damper is installed offset, inside or outside the furnace, on a 5/10 mm-thick galvanised steel sheet through duct.

The length of this duct is not specified. If the duct length is greater than 1500 mm, a supporting system will be implemented as described below, at intervals of 1500 mm, as well as additional support (collar) for the fire damper.

The fire damper is fixed to the duct using four screws (\varnothing 4.2 x 13 mm).
See drawings in the appendix.

- Protection of the duct and fire damper with a double thickness of Promastop CB or Promastop CB-CC 50 or HILTI-CFS-CT_B_1s:

The through duct is covered with a double layer composed of 50 mm-thick Promastop CB or Promastop CB-CC 50 or HILTI-CFS-CT_B_1s stone wool panels fixed to the duct using screws (\varnothing 5 x 120 mm) and washers (M6 x 44).

The fire damper casing is therefore also protected over a length of 171 mm.

The outer cross-section dimensions of this duct are (\varnothing + 200) x (\varnothing + 200) mm (w x h).

The joints between the panels, the screws and the support washers are covered with a coating of:

- Promastop E for Promastop CB
- Promastop CC for Promastop CB-CC
- Hilti CFS-S ACR for Hilti CFS-CT B

- Sealing:

Cellular concrete or plasterboard wall:

The opening (\varnothing + 600) x (\varnothing + 600) mm formed through the 100 mm thick cellular concrete wall or 100 mm thick plasterboard wall is filled by two thicknesses of 50 mm thick stone wool panels of type Promastop CB or Promastop CB-CC 50 or HILTI-CFS-CT_B_1s coated on one face with:

- Promastop E for Promastop CB
- Promastop CC for Promastop CB-CC
- Hilti CFS-S ACR for Hilti CFS-CT B

Coating

- Promastop E for Promastop CB,
- Promastop CC for Promastop CB-CC,
- Hilti CFS-S ACR for Hilti CFS-CT B,

is also applied to the joints between the stone wool panels and on the joints between the stone wool panels and the supporting construction.

Cellular concrete wall only:

The opening, with dimensions $(\varnothing + 600) \times (\varnothing + 600)$ mm and made in the cellular concrete wall (100 mm thick) is filled with standard mortar (reference CEM II/B-V-32.5N manufactured by CBR-Heidelberg) allowing the duct to be sealed.

- Duct support system:

The protection is supported by two rows of hangers 1000 mm apart. The first hanger is fixed 580 mm from the wall.

The hangers are composed of 10 mm diameter threaded rods and supporting rails with dimensions of 50 x 50 x 3 mm and 670 mm long. A distance of approximately 25 mm is kept between the threaded rods and the vertical sides of the of the stone wool enclosure.

The threaded rods and the rail are not protected.

- **For the offset installation of a cellular concrete wall or a gypsum plasterboard partition using a duct in sheet metal and protected by panels of stone wool for EI 60 performance:**

The CR 60 fire damper is installed offset, inside or outside the furnace, on a 5/10 mm-thick galvanised steel sheet through duct.

The length of this duct is not specified. If the duct length is greater than 1500 mm, a supporting system will be implemented as described below, at intervals of 1500 mm, as well as additional support (collar) for the fire damper.

The fire damper is fixed to the duct using four screws ($\varnothing 4.2 \times 13$ mm).
See drawings in the appendix.

- Protection of the duct and fire damper with Promastop CB or Promastop CB-CC 60 or HILTI-CFS-CT_B_1s:

The through duct is covered with a layer composed of 60 mm-thick Promastop CB or Promastop CB-CC 60 or HILTI-CFS-CT_B_1s stone wool panels fixed to the duct using screws ($\varnothing 5 \times 90$ mm) and washers (M6 x 44 mm).

The fire damper casing is therefore also protected over a length of 171 mm.

The outer cross-section dimensions of this duct are $(\varnothing + 120) \times (\varnothing + 120)$ mm (w x h).

The joints between the panels, the screws and the support washers are covered with a coating of:

- Promastop E for Promastop CB
- Promastop CC for Promastop CB-CC
- Hilti CFS-S ACR for Hilti CFS-CT B

- Sealing:

The opening ($\varnothing + 600$) x ($\varnothing + 600$) mm formed through the 100 mm thick cellular concrete wall or 100 mm thick plasterboard wall is filled by one thickness of 60 mm thick stone wool panels of type Promastop CB or Promastop CB-CC 60 or HILTI-CFS-CT_B_1s coated on both faces with a coating of:

- Promastop E for Promastop CB
- Promastop CC for Promastop CB-CC
- Hilti CFS-S ACR for Hilti CFS-CT B

Coating

- Promastop E for Promastop CB,
- Promastop CC for Promastop CB-CC,
- Hilti CFS-S ACR for Hilti CFS-CT B,

is also applied to the joints between the stone wool panels and on the joints between the stone wool panels and the supporting construction.

Cellular concrete wall only:

The opening, with dimensions ($\varnothing + 600$) x ($\varnothing + 600$) mm and made in the cellular concrete wall (100 mm thick) is filled with standard mortar (reference CEM II/B-V-32.5N manufactured by CBR-Heidelberg) allowing the duct to be sealed.

- Duct support system:

The protection is supported by two rows of hangers 1000 mm apart. The first hanger is fixed 580 mm from the wall.

The hangers are composed of 8 mm diameter threaded rods and supporting rails with dimensions of 35 x 35 x 2 mm and 670 mm long. A distance of approximately 25 mm is kept between the threaded rods and the vertical sides of the of the stone wool enclosure.

The threaded rods and the rail are not protected.

6.5. INSTALLATION OF FIRE DAMPERS IN PARTITIONS MADE WITH 70 MM-THICK PRECAST PLASTER TILES

The partition is made using a precast plasterboard tile assembly with dimensions 660 x 400 x 70 mm (w x h x th.) and a density of 850 kg/m³. The tiles are put together using plaster adhesive.

The tiles are installed using offset joints, with a half tile offset from one row to another. The joints are approximately 2 mm thick.

For each fire damper, an opening with dimensions ($\varnothing + 80$ mm) is made in the partition by cutting out part of the plasterboards.

On both the fire side and side away from fire, the gap between the damper tunnel and the cut-out is plugged with plaster tile adhesive.

6.6. INSTALLATION OF FIRE DAMPERS IN PLASTERBOARD WALL LINING, TYPE F ACC. EN520

- Partitioning:

This wall lining is constructed as a metal framework carrying on one side facings of double-thickness papered plasterboard panel type F acc. EN520 15 mm thick, and on the other side a layer of stone wool 40 mm thick with density 40 kg/m³; the wall lining has a total thickness of 80 mm.

- Outer framework:

The outer framework is made using 8/10 mm-thick galvanised steel R 48 rails, fixed to the concrete support frame with steel screws (Ø 4 x 45 mm) and plugs (Ø 4 mm), spaced at intervals of 600 mm.

- Central framework:

The framework for the wall lining is made using single 8/10 mm thick galvanised steel studs M 45-50, slotted into upper and lower rails and screwed at the base with a centre-to-centre distance of 600 mm.

- Header joist:

A header joist designed to allow passage of the fire damper is made using M 48-50 studs and R 48 rails.

The header joist is made of:

- Two studs added to the central framework of the partition spaced (ØD + 50) mm apart;
- An R 48 horizontal rail, cut and bent, and installed perpendicular to the additional studs at the top and bottom and spaced (ØD + 50) mm apart from one another.

The various elements are fixed together using screws (Ø 3.5 mm).

- Facings:

The plasterboard is installed with the vertical joints of one facing offset in relation to the other.

The vertical joints of the plasterboards are aligned with the studs. The plasterboards are fixed to the framework with Ø 3.5 x 25 mm self-drilling screws spaced at intervals of 700 mm for the first layer and Ø 3.5 x 35 mm screws at intervals of 250 mm for the second layer.

The visible joints between the plasterboards and the return angles with the concrete frame are treated using the PREGYLYS (LAFARGE) filler + jointing tape technique. The screw heads are also covered with the same coating.

- Sealing around the fire damper:

Solution 1:

The joint between the fire damper duct and the wall is plugged with stone wool with a density of 40 kg/m³. The clearance between the tunnel and the wall is approximately 25 mm. On the facing side, a 100 mm-wide strip of GKF-type gypsum plasterboard 15 mm thick is fixed to the wall every 250 mm using self-drilling steel M6 screws above this space. The screws are also covered with PREGYLYS (LAFARGE) coating.

Solution 2:

The joint between the CR60 and CR120 fire damper casing and the wall is plugged with stone wool with a density of 60 kg/m³. The clearance between the tunnel and the wall is approximately 25 mm. On the facing side, the free space between the fire dampers and the wall, previously filled with stone wool, is covered with a layer of PREGYLYS (LAFARGE) type filler, spread across the fire damper casing and the supporting construction over a minimum length of 50 mm, so as to ensure the two surfaces are perfectly sealed.

7. FIRE RESISTANCE CLASSIFICATIONS

7.1. CLASSIFICATION REFERENCE

This classification procedure was conducted in accordance with section 7.2.4 of the standard EN 13501-4.

7.2. CLASSIFICATIONS

The elements are classified in accordance with the following combinations of performance parameters and classes.

The dimensional range covered by the performances stated below is from Ø 100 mm to Ø 315 mm, except for installation in 98/48-type plasterboard panel partitions, where the dimensions are from Ø 100 mm to Ø 250 mm.

No other classification is authorised.

7.2.1. Without kit / option 1S

- For CR60 fire dampers installed in:

- plasterboard wall linings, type F acc. EN250 (with or without stubs) thickness 80 mm.

Fire dampers dimensions are between Ø 100 mm and Ø 315 mm.

E	I		t		ve	-	ho	-	i	↔	o	-	S
E	I		60		ve	-		-	i	↔	o	-	S

- For CR60 fire dampers installed in:

- 70 mm-thick plaster tile panel partitions

Fire dampers dimensions are between Ø 100 mm and Ø 315 mm.

E	I		t		ve	-	ho	-	i	↔	o	-	S
E	I		90		ve	-		-	i	↔	o	-	S

- For CR60 fire dampers installed in plasterboard panel partitions, type F / type A acc. EN520 thickness 100 mm:

Fire dampers dimensions are between Ø 100 mm and Ø 250 mm.

E	I		t		ve	-	ho	-	i	↔	o	-	S
E	I		60		ve	-		-	i	↔	o	-	S

- For CR60 fire dampers installed in plasterboard panel partitions, type F / type A acc. EN520 thickness 100 mm, plaster sealing:

Fire dampers dimensions are between Ø 100 mm and Ø 315 mm.

E	I		t		ve	-	ho	-	i	↔	o	-	S
E	I		90		ve	-		-	i	↔	o	-	S

- For CR60 fire dampers built into:

- A 100 mm-thick cellular/reinforced concrete wall
- A 100 mm-thick cellular/reinforced concrete slab.

Fire dampers dimensions are between Ø 100 mm and Ø 315 mm.

E	I		t		ve	-	ho	-	i	↔	o	-	S
E	I		90		ve	-	ho	-	i	↔	o	-	S

For the approval of offset fire dampers using a sheet metal duct protected by stone wool:

The maximum approved operating vacuum pressure in this case is -300Pa.

Where seal is made using panels of PROMASTOP CB or Promastop CB-CC 50 or HILTI-CFS-CT_B_1s with th = 2 x 50 mm

E	I	-	t		ve	ho	i	<->	o	S
E	I		90		Ve		i	<->	o	S

Where seal is made using panels of PROMASTOP CB or Promastop CB-CC or HILTI-CFS-CT_B_1s with th = 1 x 60 mm

E	I	-	t		ve	ho	i	<->	o	S
E	I		60		Ve		i	<->	o	S

For the approval of offset fire dampers using a sheet metal duct protected by panels of GEOFLAM F 45 or **Geoflam f light 35 or Geotec s 45**:

The maximum approved operating vacuum pressure in this case is -500Pa.

E	I	-	t		ve	ho	i	<->	o	S
E	I		90		Ve		i	<->	o	S

For the approval of offset fire dampers using a duct made of panels of GEOFLAM F 45 or **Geoflam f light 35** or **Geotec s 45**:

The maximum approved operating vacuum pressure in this case is -500Pa.

E	I	-	t		ve	ho	i	<->	o	S
E	I		90		ve		i	<->	o	S

7.2.2. With kit / option 1S

- For fire dampers CR60 with kit / option 1S installed in:
 - Partitions thickness of 100 mm in plasterboard type A (EN 520)
 - Wall linings thickness of 80 mm in plasterboard type F (EN 520)

Fire dampers dimensions are between Ø 100 mm and Ø 315 mm.

E	I		t		ve	-	ho	-	i	↔	o	-	S
E	I		60		ve	-		-	i	↔	o	-	S

- For fire dampers CR60 with kit / option 1S installed in a cellular concrete wall of thickness of 100 mm:

Fire dampers dimensions are between Ø 100 mm and Ø 315 mm.

E	I		t		ve	-	ho	-	i	↔	o	-	S
E	I		60		ve	-		-	i	↔	o	-	S

- For fire dampers CR60 with kit / option 1S installed in a cellular concrete slab thickness 100 mm:

Fire dampers dimensions are between Ø 100 mm and Ø 315 mm.

E	I		t		ve	-	ho	-	i	↔	o	-	S
E	I		60			-	ho	-	i	↔	o	-	S

- For fire dampers CR60 with kit / option 1S installed in a cellular concrete slab thickness 100 mm:

Fire dampers dimensions are between Ø 100 mm and Ø 315 mm.

E	I		t		ve	-	ho	-	i	↔	o	-	S
E	I		90			-	ho	-	i	→	o	-	S

The above performances of the elements are valid for heating as described in section 5.1.1 of the European standard EN 1363-1

8. SCOPE OF APPLICATION OF THE RESULTS

8.1. GENERAL POINTS

The requirements related to the scope of application of all the fire dampers tested in accordance with EN 1366-2 apply, as well as the following items.

8.2. DIMENSIONS OF THE FIRE DAMPER

In accordance with section 13.1 of the standard EN 1366-2, the classifications indicated in section 7.2 of this classification report are valid for all fire dampers of the same type (including all the side reports), provided the maximum flow cross-section dimensions do not exceed \varnothing 315 mm and that the minimum flow cross-section dimensions are not less than \varnothing 100 mm.

8.3. SEPARATION BETWEEN FIRE DAMPERS AND BETWEEN FIRE DAMPERS AND CONSTRUCTION ELEMENTS

In accordance with section 13.5 of the standard EN 1366-2, the fire classifications indicated in section 7.2 of this classification report apply, in practice, with a minimum spacing:

- a) of 200 mm between fire dampers installed in separate ducts;
- b) of 75 mm between the fire damper and a construction element (wall or boards).

8.4. SUPPORTING CONSTRUCTIONS

In accordance with section 13.6.1. of standard NF EN 1366-2, the classifications stated at section 7.2 of this classification report are applicable only to dampers installed through or offset from a cellular concrete wall of minimum thickness 100 mm and having minimum density 550 kg/m³, through a cellular concrete slab of minimum thickness 100 mm and minimum bulk density 650 kg/m³, through a reinforced concrete slab of minimum thickness 100 mm and minimum bulk density 2200 kg/m³, or installed through or offset from a support construction of the same type as the standardised non-rigid support construction used in the test, of fire resistance level as good or better (greater thickness, higher density, more layers of panels as may be the case).

The test result may also apply to hollow masonry blocks or slabs possessing a fire resistance time that is equal to or greater than the one stated for the installation of the fire damper.

If a specific supporting construction, different to those mentioned above, is chosen – in this case, a 70 mm-thick plasterboard panel wall with a density of 850 kg/m³ – the test results obtained are only applicable to this specific wall, partition or floor if it has a greater thickness or density than that of the test.

No modifications may be applied to the dimensions expressed above and no modifications may be made to the structure of the element without the prior issue of a classification extension by the laboratory.

Issued in Maizières-lès-Metz, 08 June 2017







Romain Stouvenot
Head of Projects



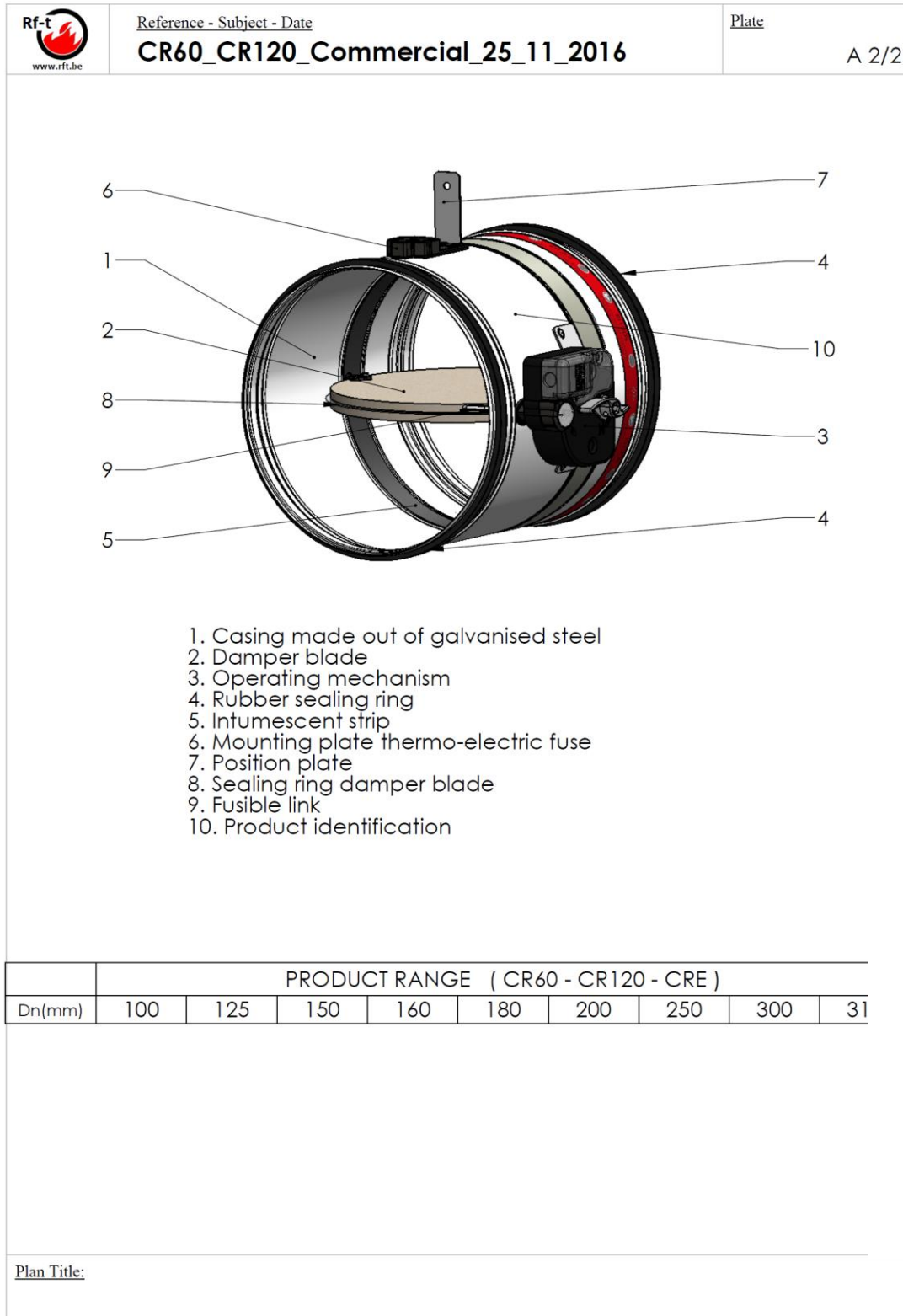



Mathieu Fenucci
Technical Director, Smoke extraction

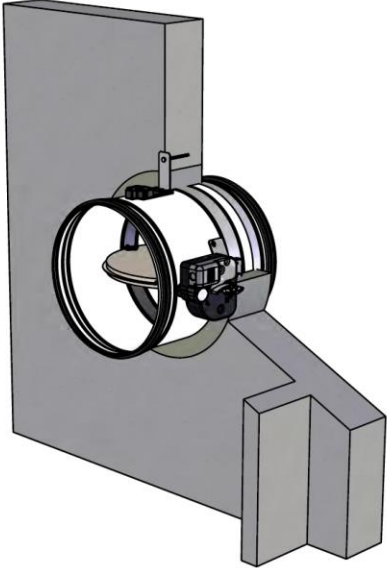
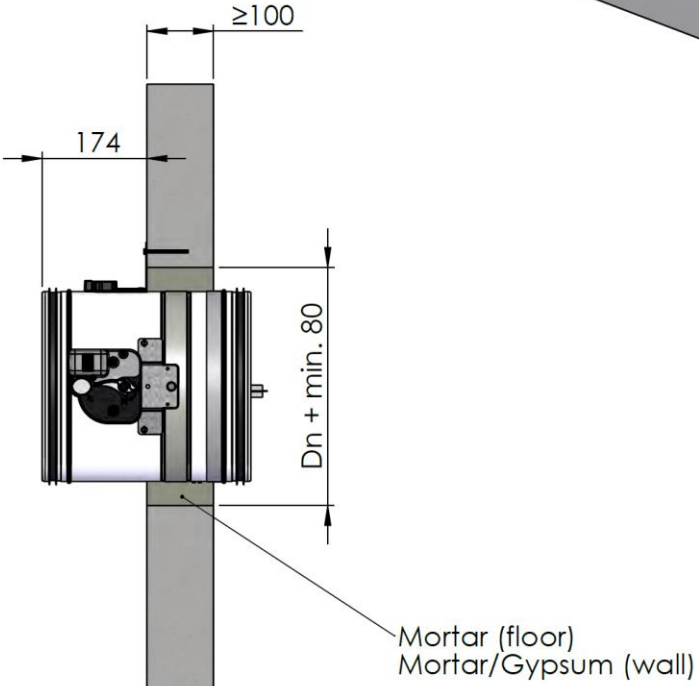

APPENDIX: FIGURES

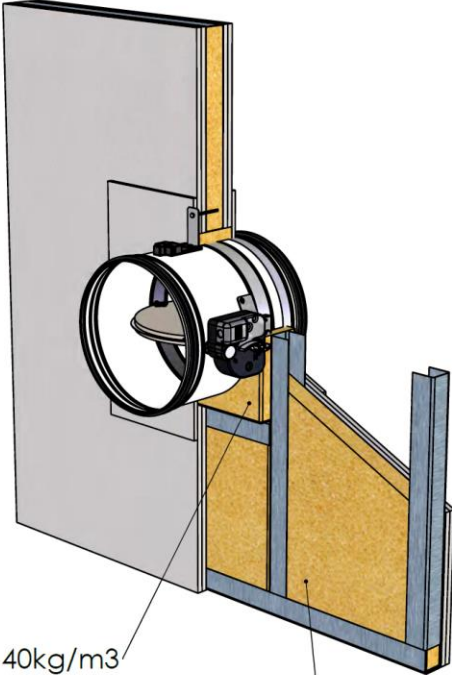
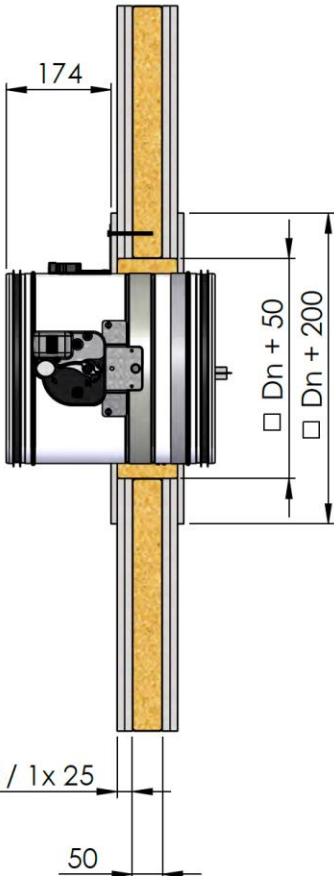



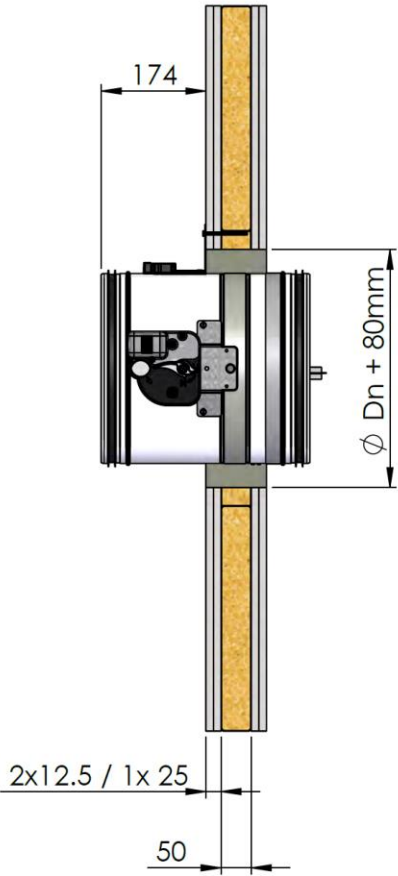
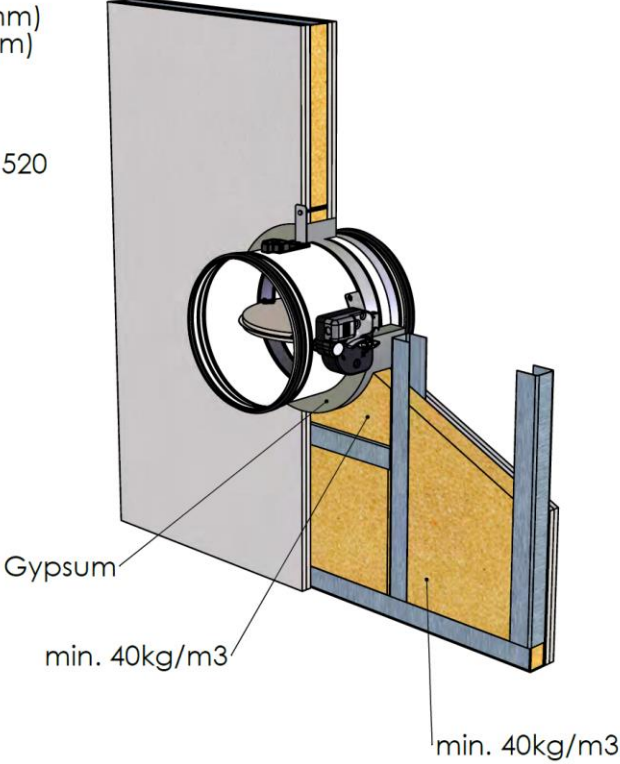

 www.rf.t.be	Reference - Subject - Date CR60_CR120_Installation_10_05_2017	Plate E 2/15
<p>Rigid wall and floor</p> <div style="display: flex; align-items: center; margin-bottom: 20px;"> <div style="margin-right: 10px;">  </div> <div style="margin-right: 10px;">  </div> <div> <p>90'/120'</p> </div> </div> <div style="display: flex; justify-content: space-around;"> <div style="text-align: center;">  </div> </div> <div style="margin-top: 20px;">  <p style="margin-left: 350px;"> ≥ 100 174 $D_n + \text{min. } 80$ Mortar (floor) Mortar/Gypsum (wall) </p> </div>		
<p><u>Plan Title:</u></p>		

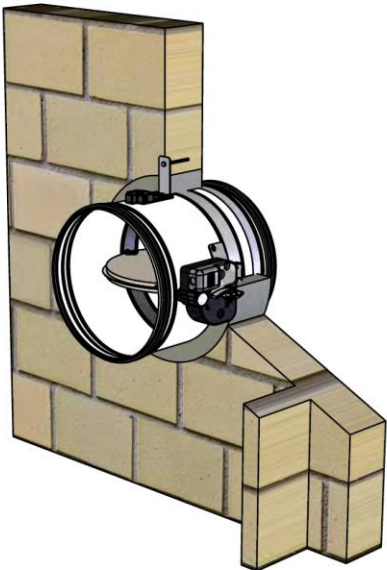
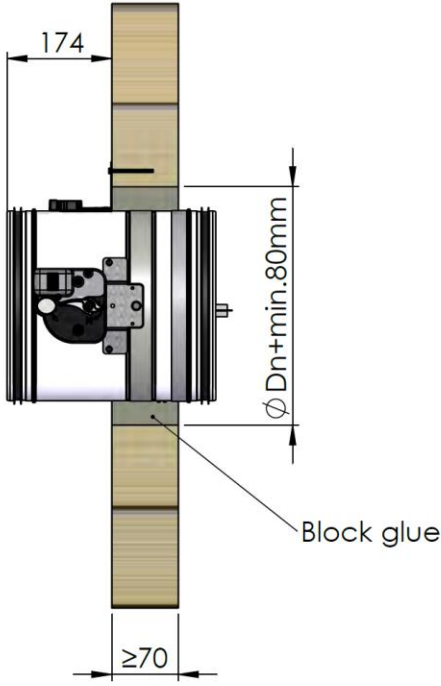
 www.rf.t.be	Reference - Subject - Date CR60_CR120_Installation_10_05_2017	Plate E 3/15
<p>Flexible wall - Metal stud gypsum plasterboard wall</p>		
	type A 60' (\varnothing 100-250mm) type F 90' (\varnothing 100-250mm)	
<p>Gypsum wall type A/F acc EN 520</p>		
 <p>174</p> <p>$\square Dn + 50$</p> <p>$\square Dn + 200$</p> <p>2x12.5 / 1x25</p> <p>50</p>	<p>min. 40kg/m³</p>	<p>min. 40kg/m³</p>
<p>Plan Title:</p>		

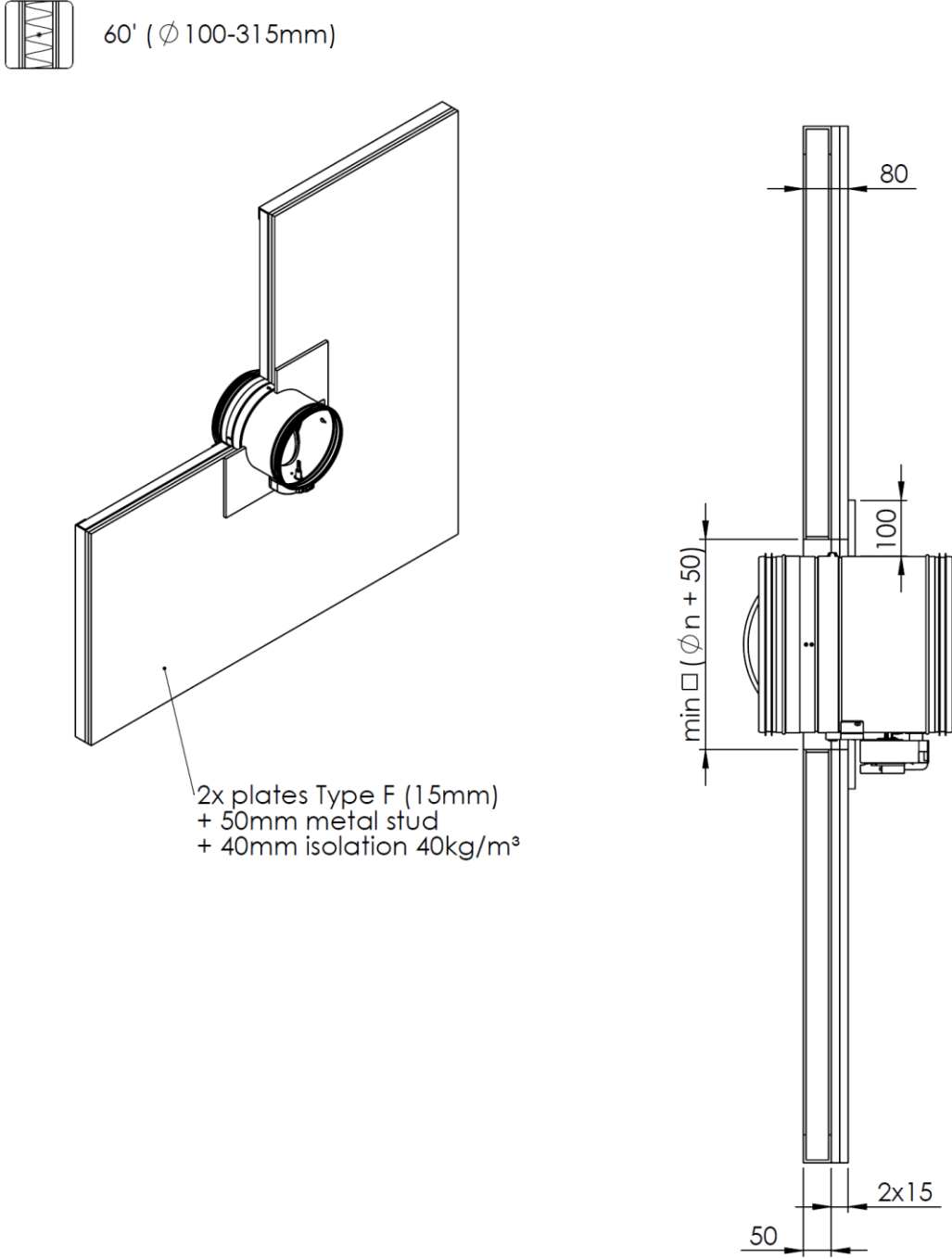
 <p>www.rf.t.be</p>	<p>Reference - Subject - Date CR60_CR120_Installation_10_05_2017</p>	<p>Plate E 5/15</p>
<p>Flexible wall - Metal stud gypsum plasterboard wall</p> <p>  type A 60' (\varnothing 100-315mm) type F 90' (\varnothing 100-315mm) </p> <p>Gypsum wall type A/F acc EN 520</p> <div style="display: flex; justify-content: space-around;"> <div data-bbox="300 1048 699 1921">  <p>174</p> <p>50</p> <p>\varnothing Dn + 80mm</p> <p>2x12.5 / 1x 25</p> </div> <div data-bbox="726 571 1348 1332">  <p>Gypsum</p> <p>min. 40kg/m³</p> <p>min. 40kg/m³</p> </div> </div> <p>Plan Title:</p>		

 <p>www.rf.t.be</p>	<p>Reference - Subject - Date CR60_CR120_Installation_10_05_2017</p>	<p>Plate E 6/15</p>
<p><u>Gypsum block wall</u></p>		
	<p>120'</p>	
 <p>174</p> <p>$\varnothing D_n + \text{min. } 80\text{mm}$</p> <p>Block glue</p> <p>≥ 70</p>		
<p><u>Plan Title:</u></p>		

 www.rf.t.be	Reference - Subject - Date CR60_CR120_Installation_10_05_2017	Plate E 7/15
<p>Shaft wall - Metal stud gypsum plasterboard wall</p>  <p>60' (ϕ 100-315mm)</p> <p>2x plates Type F (15mm) + 50mm metal stud + 40mm isolation 40kg/m³</p>		
<p><u>Plan Title:</u></p>		

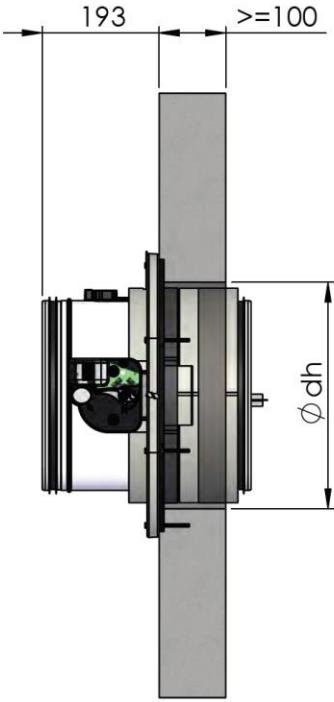
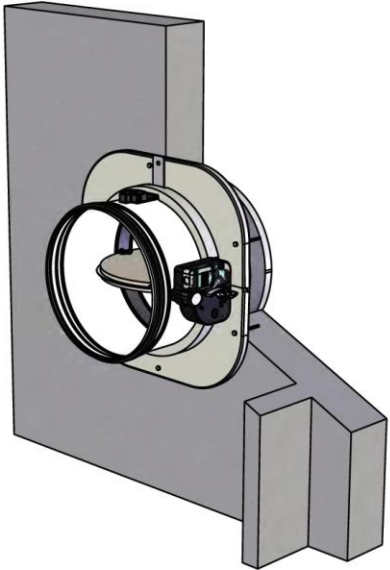
	<p>Reference - Subject - Date CR60_CR120_Installation_10_05_2017</p>	<p>Plate E 11/15</p>														
<p>Rigid wall, floor and ceiling</p>																
		<p>60'</p>														
		<table border="1"> <thead> <tr> <th>ϕ Dn</th> <th>ϕ dh</th> </tr> </thead> <tbody> <tr> <td>100</td> <td>180</td> </tr> <tr> <td>125</td> <td>200</td> </tr> <tr> <td>160</td> <td>240</td> </tr> <tr> <td>200</td> <td>275</td> </tr> <tr> <td>250</td> <td>320</td> </tr> <tr> <td>315</td> <td>375</td> </tr> </tbody> </table>	ϕ Dn	ϕ dh	100	180	125	200	160	240	200	275	250	320	315	375
ϕ Dn	ϕ dh															
100	180															
125	200															
160	240															
200	275															
250	320															
315	375															
<p>Plan Title:</p>																

 <small>www.rf.t.be</small>	<p>Reference - Subject - Date</p> <p>CR60_CR120_Installation_10_05_2017</p>	<p>Plate</p> <p>E 12/15</p>
---	--	-----------------------------

Flexible wall - Metal stud gypsum plasterboard wall

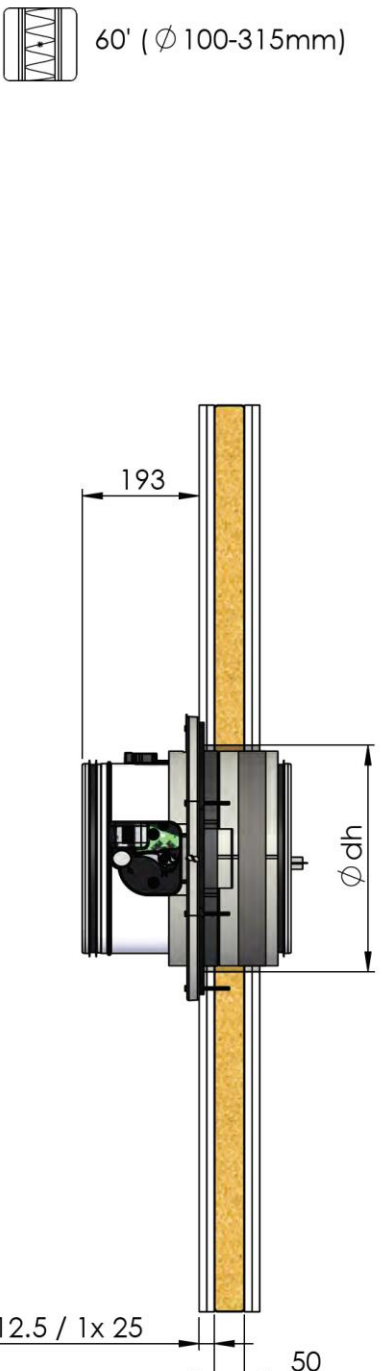

60' (Ø 100-315mm)

193

Ø dh

2x12.5 / 1x 25

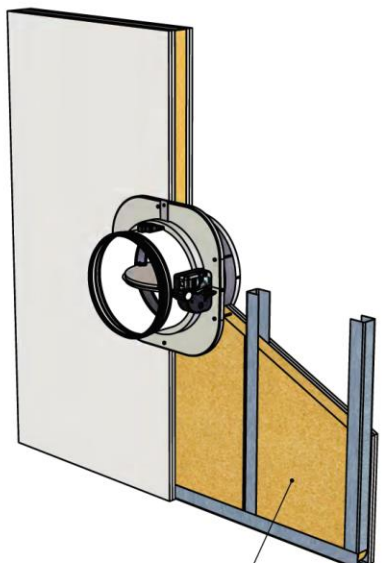

50



min. 40kg/m³

Ø Dn	Ø dh
100	180
125	200
160	240
200	275
250	320
315	375

Plan Title:

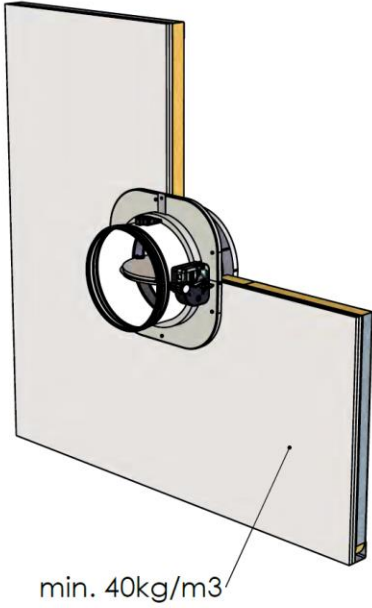
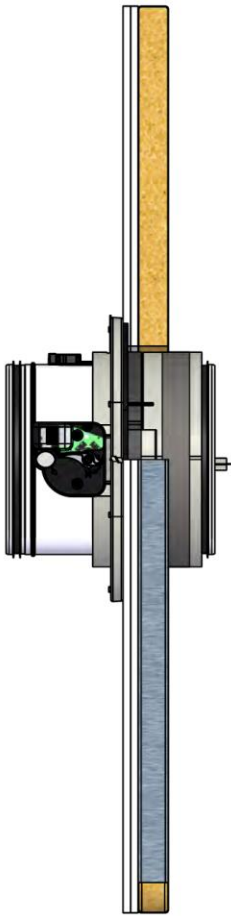
	<p>Reference - Subject - Date CR60_CR120_Installation_10_05_2017</p>	<p>Plate E 13/15</p>														
<p>Shaft wall - Metal stud gypsum plasterboard wall</p>																
	<p>60' (ϕ 100-315mm)</p>	 <p>min. 40kg/m3</p>														
	<table border="1"> <thead> <tr> <th>ϕ Dn</th> <th>ϕ dh</th> </tr> </thead> <tbody> <tr> <td>100</td> <td>180</td> </tr> <tr> <td>125</td> <td>200</td> </tr> <tr> <td>160</td> <td>240</td> </tr> <tr> <td>200</td> <td>275</td> </tr> <tr> <td>250</td> <td>320</td> </tr> <tr> <td>315</td> <td>375</td> </tr> </tbody> </table>	ϕ Dn	ϕ dh	100	180	125	200	160	240	200	275	250	320	315	375	
ϕ Dn	ϕ dh															
100	180															
125	200															
160	240															
200	275															
250	320															
315	375															
<p>Plan Title:</p>																

 www.rf.t.be	Reference - Subject - Date	Plate
	CR60_CR120_Installation_10_05_2017	E 14/15

Mounting outside the wall

60' and 90' Solution

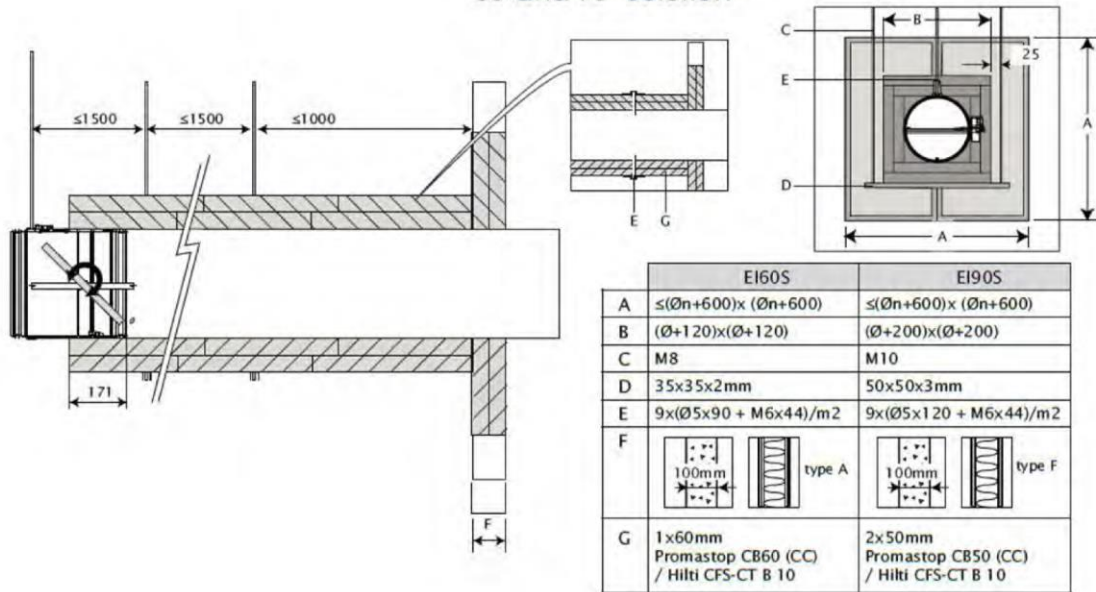

120' Solution

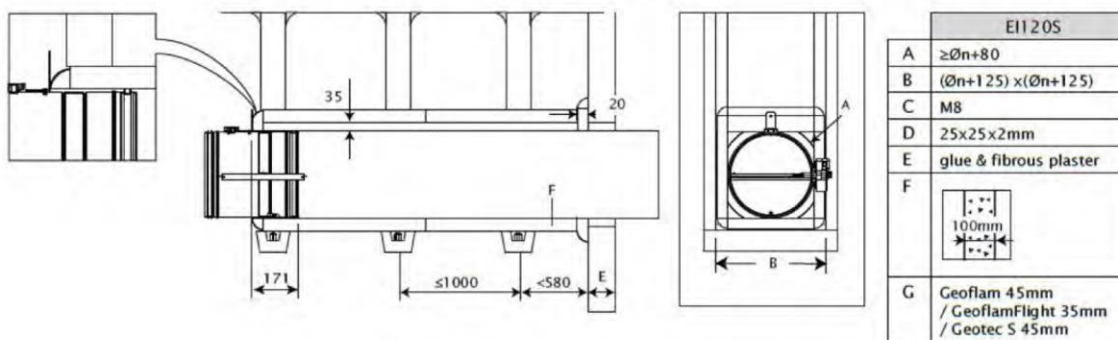

Plan Title:



Reference - Subject - Date

CR60_CR120_Installation_10_05_2017

Plate

E 15/15

Mounting flexible wall at 0 distance

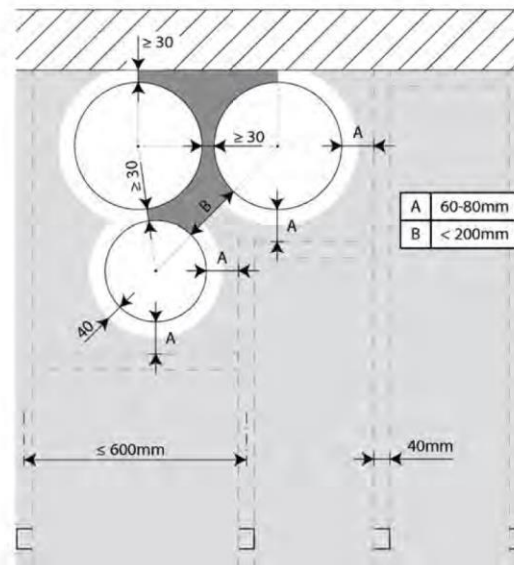

Mounting rigid wall at 0 distance

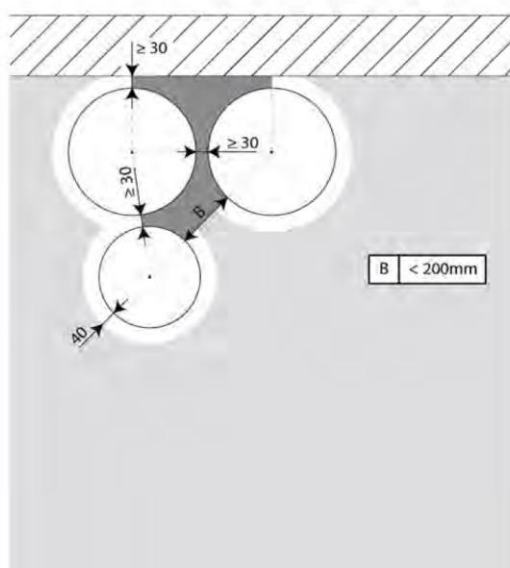

Plan Title: